

JOHNSON[®]



JOHNSON[®]



Johnny Square[®]

7" Aluminum Rafter Angle Square

Équerre d'angle en aluminium pour chevrons 7 po
Escuadra 7" en aluminio para envigado



Continuous Scribing Notches-Ideal for Ripping at 3-1/2" and 5-1/2"

Encoches de traçage continues, parfaites pour coupe en long à 3 1/2 po et à 5 1/2 po
Muecas para marcaciones d'continuas - ideales para cortes a 3-1/2" y 5-1/2"



Durable Powder Coat Finish

Fini poudre durable
Capa protectora anti-corrosiva

MARKING EDGE
Bord de marquage
Borde para marcado

SCRIBING NOTCHES (1" TO 5-1/2")
Encoches de traçage (1 po à 5 1/2 po)
Muecas para marcaciones (1" y 5-1/2")

PIVOT
Pivot
Pivote

RAFTER SEAT CUT
Coupe de siège du chevron
Indicación para corte de asiento

1/4" SCALE (1" TO 3-1/2")
Échelle en 1/4 po (1 po à 3 1/2 po)
Escala de 1/4" (entre 1" y 3-1/2")

**TOP CUTS/
HIP & VALLEY
RAFTER SCALE**
Échelle pour coupes d'arrêtiers et de noues
Escala para cortes superiores y cortes en ángulo estilos Hip y Valley

COMMON RAFTER SCALE
Échelle courante pour les angles de chevrons
Escala común para ángulos de vigas

"T"-BAR (FOOT)
Talon en forme de T
Base para ángulo recto

**DEGREE SCALE/
PROTRACTOR**
Échelle degrés/rapporteur
Escala de grados/transportador



Made in USA
Fabriqué aux États-Unis / Hecho en EE.UU.
©2019 Johnson Level & Tool Mfg. Co., Inc.
Mequon, WI 53092
Montréal, Québec, Canada
www.johnsonlevel.com
www.johnsonlevel.com/patents



RAS-1



7"
18cm

RAS-1

JOHNSON[®]

The versatility and durability of Johnson's "Johnny Square[®]" came from professional master carpenter Johnny Wong, an accomplished homebuilder with more than twenty-five years experience in the trades.

Johnny's crews were never satisfied with their rafter squares ability to mark lumber for rip cuts. Johnson solved this problem by delivering a square with continuous scribing notches, and the Johnny Square[®] was born.



Johnson[®]—TOUGH, RELIABLE, ACCURATE

The Johnson® Rafter Angle Square

Thank you for purchasing the Johnson® Rafter Angle Square. Since 1947 Johnson Level & Tool has been developing solutions to help professional tradesmen improve their work. Our products are trusted by professionals worldwide to work more accurately, more quickly and more reliably.

This reference book will serve as a guide for providing basic rafter and angle layout information through various illustrations and tables. *Johnson Level & Tool is not responsible for any errors or omission with the content of this book. The information outlined is to be used as a recommendation however other methods not listed may be acceptable practice.*

The Johnson® Rafter Angle Square is available in 7 inch and 12 inch sizes to accommodate various material dimensions.

Here's what makes Johnson® Rafter Angle Squares fast and efficient:

- The new and improved 7 inch has continuous scribing grooves from 1 inch through 5-1/2 inches. (Please see illustration 1 on page 2)
- Easy to read angle scale from 0° to 180°.
- One number layout for: Roofs, solar panel supports, stairs, cabinets, trim work and many other layout projects.
- The rafter scales are laid out mathematically to avoid time consuming calculations.
- The 12 inch has continuous 1/4 inch scribing grooves from 1-3/4 inches through 9 inches.
- Both rafter angle square models serve as a saw guide for fast cuts.

For additional information on the Johnson® Rafter Angle Square family of products please visit www.johnsonlevel.com

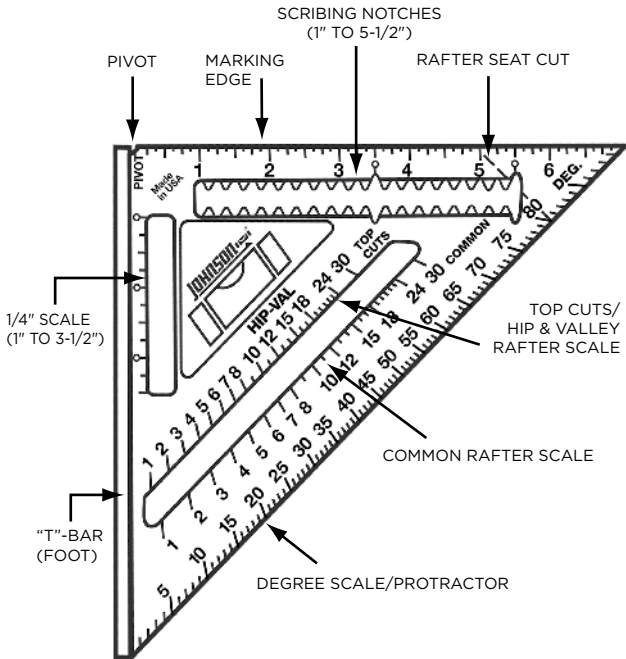

TABLE OF CONTENTS

Types of Rafters	4
Rafter Measurements	6
Inches to Feet Conversion (Table A)	9
Common Rafters	9
Common Rafter Layout	12
Hip and Valley Rafters	15
Hip Rafter Layout.	18
Intersection of Hips on Ridge.	19
Valley Rafter Layout	20
Jack Rafters.	22
Jack Rafter Layout	25
Dormer Rafters	26
Door Overhang	26
Degree Scale	27
Stair Layout Example	28
Solar Panel Layout Example.	34
Rafter Length Tables.	40

TYPES OF RAFTERS

COMMON RAFTER: A rafter that runs perpendicular (90°) from the wall plate to the roof ridge when looking straight down at the roof. When looking from the side, its length forms the diagonal leg (or hypotenuse) of a right triangle that has its vertical leg equal to the rise and its horizontal leg equal to the run (see Figures 1, 3 and 8).

VALLEY RAFTER: A rafter that runs from the wall plate to the roof ridge at the intersection of the gable extension with the main roof (see Figures 1, 8, 12 and 13).

VALLEY JACK RAFTER: A rafter that runs from a valley rafter to the roof ridge, 90° from the roof ridge (see Figures 1, 8 and 15).

HIP RAFTER: A rafter that runs diagonally from the top of the wall plate to the roof ridge, so as to form an outside corner of the roof (see Figures 1, 8, 9 and 10).

HIP JACK RAFTER: A rafter that runs from the top of the wall plate to a hip rafter at 90° to the wall plate (see Figures 1, 8 and 14).

CRIPPLE JACK RAFTER: A rafter that runs from a hip rafter to a valley rafter, perpendicular to the roof ridge (see Figures 1 and 8).

DORMER RAFTER: A rafter which sets on top of the main roof without cutting into it, thus causing the main roof not to weaken. For example, when remodeling or when solar panels are added (see Figure 1).

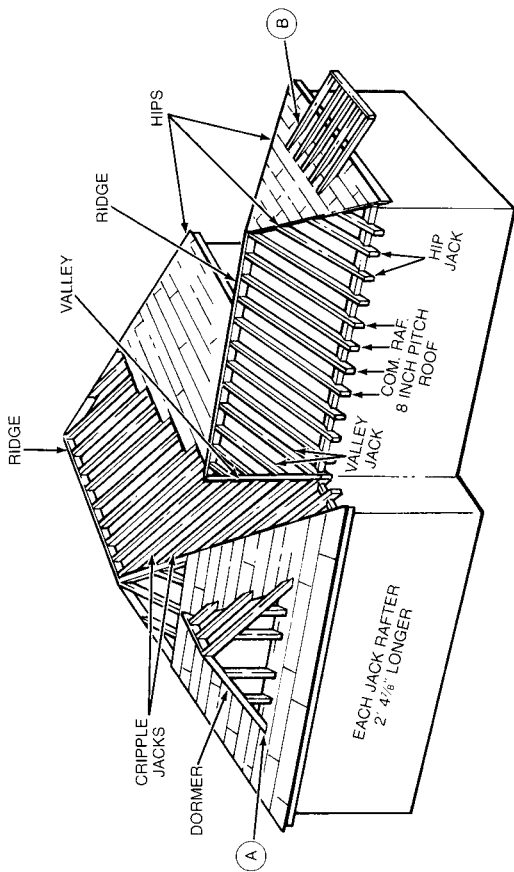

FIG. 1 Types of Rafters. All cuts on this roof can be made by using the number 8 (i.e. an 8 inch rise).

RAFTER MEASUREMENTS

The use of our square for rafter layout is based on two simple and common building measurements: (1) the rafter run, and (2) the rafter rise. These are available from either the building blueprints, drawings, or actual measurements. The tables included in the back of this book are also based on these two simple measurements (see Figures 2 and 3, and also the tables starting on page 40).

RAFTER RUN: Run is the horizontal or level distance the rafter will span. It is measured in feet.

RAFTER RISE: Rise is the vertical distance of a rafter between its highest and lowest points. It is measured in feet.

INCH RISE: The rise measured in inches per foot run. It is also called “Inch Rise Per Foot Run.” It can be calculated with the following formula:

$$\begin{array}{ccc} \text{INCH RISE} & & \text{RAFTER RISE (ft) x 12} \\ \text{OR} & = & \hline \text{(SCALE NUMBER)} & & \text{RAFTER RUN (ft)} \end{array}$$

The Inch Rise gives you the corresponding scale number to use on the square (for the common & hip-val scales). It is also the “one number by which you can frame the roof.”

The inch rise, the rafter run and the tables in the back of the book are all that are needed to lay out rafter lengths and the cuts for common, hip, valley and jack rafters. The instructions outlined below show the step-by-step procedure to follow for basic roof construction.

STEP 1. OBTAIN RAFTER RUN: Measure or calculate the horizontal distance the rafter will span, starting at the outside of the wall on which it will rest. Include any boarding on the wall if it extends to the wall top plate (see Figure 3).

When measuring building width to obtain rafter run, use a steel tape if possible so that you can measure the full width of the building. Measure from outside to outside of the wall or the top plate on which the rafter will rest. If boarding extends up to the top plate, measurement is to be taken from outside of the boarding.

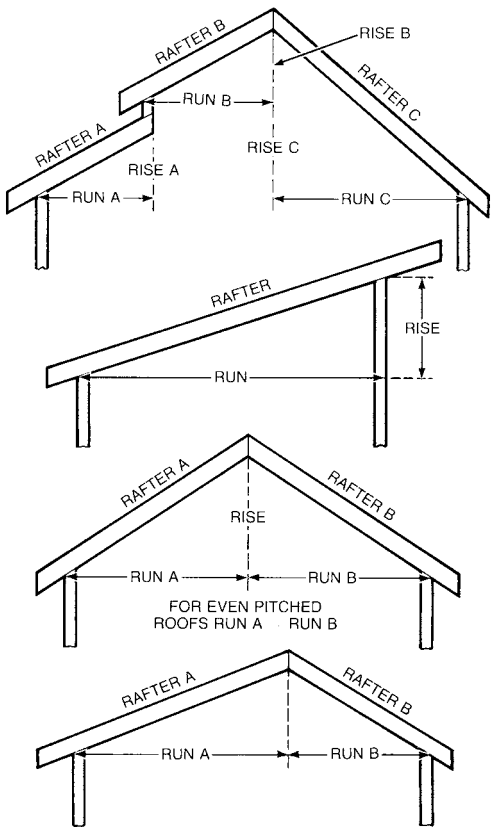

FIG. 2 Rafter Runs and Rises for Different Style Roofs.

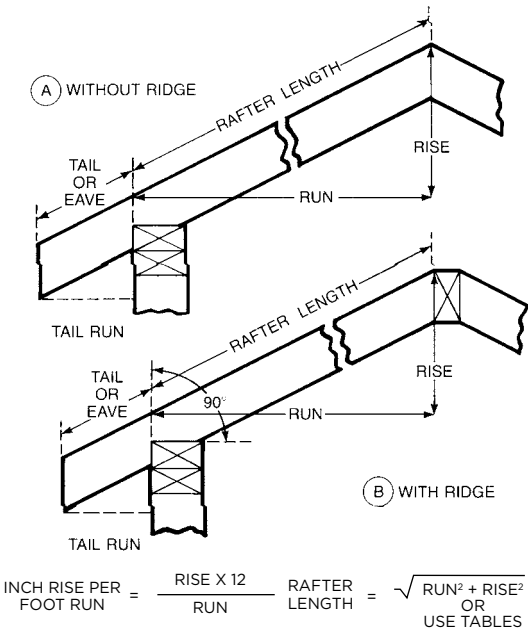

FIG. 3 The Common Rafter.

Then the run is found by dividing in half the building width. When a ridge board is being used, deduct 1/2 its thickness from the run.

STEP 2. OBTAIN ROOF RISE: Find the distance you wish the roof ridge to be above the wall (in feet) by measuring, calculating or obtaining it from the blueprints (see Figure 2).

TABLE A

Change Inches to Feet

1" = .08'	7" = .58'
2" = .16'	8" = .67'
3" = .25'	9" = .75'
4" = .33'	10" = .83'
5" = .42'	11" = .92'
6" = .50'	

STEP 3. CALCULATE INCH RISE: For example, with the Run = 13' 0" and Rise = 8' 9". First convert the rise to feet in decimal form, using TABLE A. Therefore, the Rise = 8.75'. Now, using the formula for the "Inch Rise":

$$\text{Inch Rise} = \frac{8.75' \times 12}{13'} = 8.08 \text{ in/ft. Run}$$

Round off the Inch Rise to the nearest inch. Since rounding off won't make much difference in most cases. It will make the actual roof rise slightly higher or lower. In this example, rounding to 8 will make the height 8' 8" instead of 8' 9". Rounding off this figure has more of an effect on buildings with longer rafter runs or higher roof rises. If the Inch Rise is given on a blueprint, this calculation is not needed, just use the one given. Now, let us do an example of each type of rafter.

COMMON RAFTERS

COMMON RAFTER LENGTH: After the Inch Rise and Run are found, use the tables in the back of this book to find the common rafter length. In our example an 8 Inch Rise is used, therefore find the 8 Inch Rise table (on page 47) and go down the left hand column headed "Run Ft." and locate 13'. To the right, read the column headed "Common Rafter Length" for the rafter

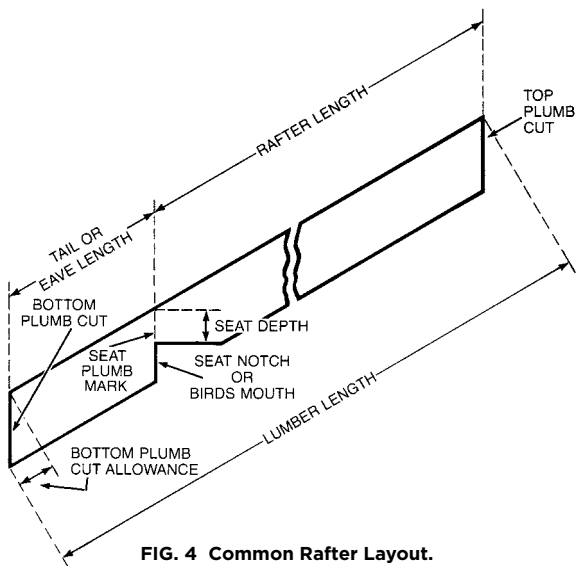
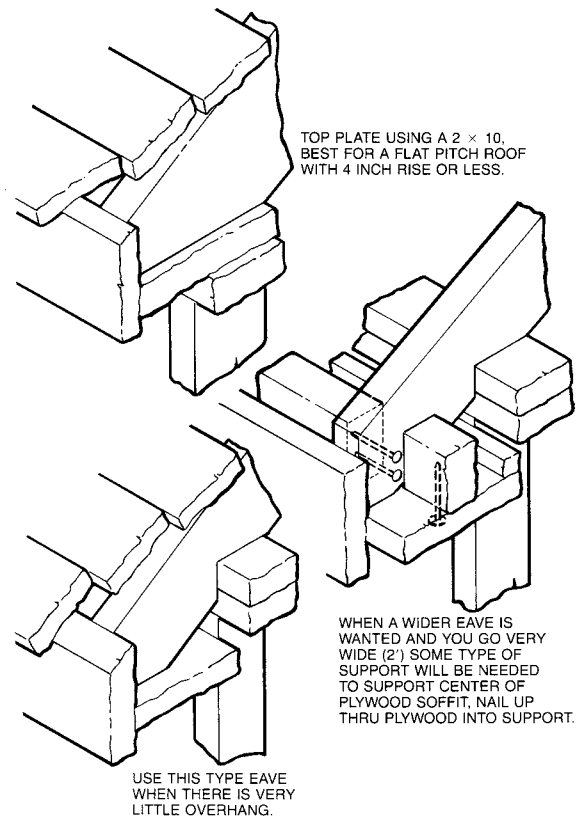

FIG. 4 Common Rafter Layout.

length. For our rafter we get 15' 7-1/2". This is the rafter length from the top plumb cut to the seat plumb mark (see Figure 4).

NOTE: For a run greater than that given in the tables, simply add any two runs that will equal the run desired. Then find the lengths for those two rafters and add them together. For example, say that your run is 38', add the length for a 18' run and the length for a 20' run together. Or add a 15' run's length and a 23' run's length together.

TAIL OR EAVE LENGTH: The tail or eave overhang now must be added to the rafter length (see Figure 5 for suggested eave construction). With our example, let us use



TOP PLATE USING A 2 × 10,
BEST FOR A FLAT PITCH ROOF
WITH 4 INCH RISE OR LESS.

USE THIS TYPE EAVE
WHEN THERE IS VERY
LITTLE OVERHANG.

WHEN A WIDER EAVE IS
WANTED AND YOU GO VERY
WIDE (2') SOME TYPE OF
SUPPORT WILL BE NEEDED
TO SUPPORT CENTER OF
PLYWOOD SOFFIT, NAIL UP
THRU PLYWOOD INTO SUPPORT.

FIG. 5 Suggested Eave Construction.

a tail run of 1' 9". In the same "Common" table as used above, for an 8" rise, we find:

$$\begin{array}{r} 1' \text{ Run} = 1' 2\text{-}1/2'' \\ 9'' \text{ Run} = 10\text{-}7/8'' \\ \hline 1' 9'' \text{ Tail} = 2' 1\text{-}3/8'' \end{array}$$

COMMON RAFTER LUMBER LENGTH: To obtain the total length of the rafter, an allowance for the bottom plumb cut must now be made (see Figure 4). This allowance can be obtained by using the tables. In our example, let us use a 2 x 6 piece of lumber which will give us a depth of 5 1/2 inches. From the bottom allowance table (using 8" rise again), the common and jack allowance equals 3-11/16 inches. The total common rafter lumber length then becomes:

RAFTER LENGTH	= 15' 7-1/2"
TAIL	= 2' 1-3/8"
BOTTOM ALLOWANCE	= 3-11/16"
TOTAL LUMBER LENGTH	= 18' 0 9/16"

COMMON RAFTER LAYOUT

STEP 1. TOP PLUMB CUT: In choosing the side of your rafter to use, put the crown (high side) up if the rafter is not straight. Now starting at the top of the rafter, lay our square on the face of the rafter so that the "T" bar is draped over the top edge of the rafter (see Figure 6). While holding the pivot point firmly against the edge of the rafter, pivot the square so that the number 8 on the common scale lines up with the edge of the rafter. Starting from the pivot point, mark the top plumb cut line along the top edge of the square.

STEP 2. SEAT NOTCH OR BIRD'S MOUTH: With your rafter length (in our example 15' 7-1/2"), measure down along the top edge of the rafter and mark another plumb line as you did in Step 1. This line represents the outside wall of your

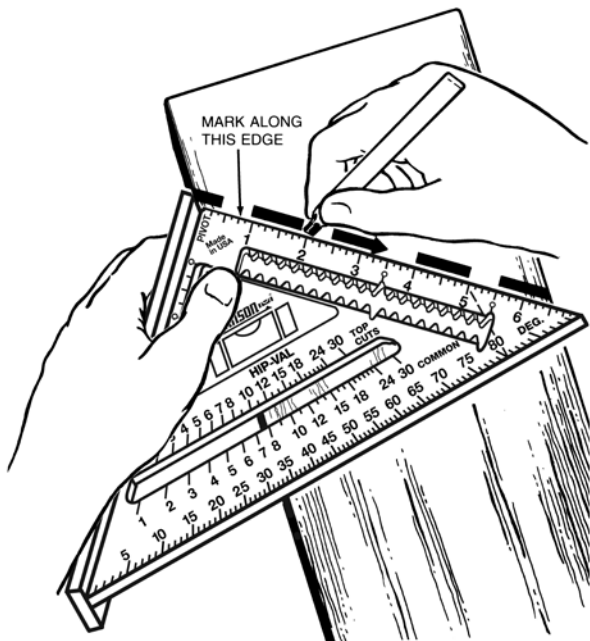

DRAWING SHOWS SQUARE IN POSITION FOR MARKING TOP PLUMB CUT OF A COMMON RAFTER WITH AN 8" RISE, ALSO SHOWING A 33 $\frac{3}{4}$ ° ANGLE.

FIG. 6 Top Plumb Cut of a Common Rafter.

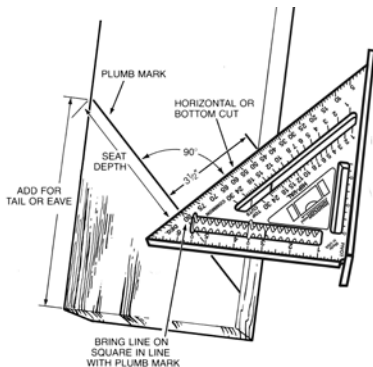

FIG. 7A
Seat Notch or
Bird's Mouth Layout.

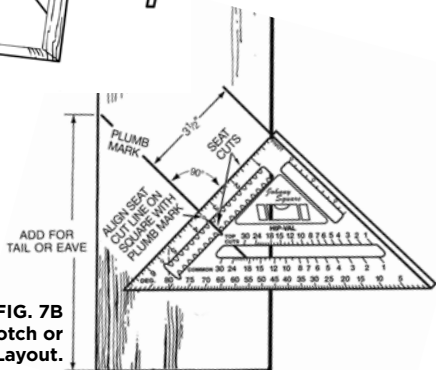

FIG. 7B
Seat Notch or
Bird's Mouth Layout.

building. Now line up the dashed line (above the 80° increment on the square) with the plumb mark (see Figure 7A & 7B). Draw the horizontal seat mark, a perpendicular line, along the bottom of square. Never notch more than halfway through the rafter and make all seat notches the same depth.

STEP 3. TAIL OR BOTTOM PLUMB CUT: Using your tail length (2' 1-3/8" in our example), measure down the rafter from the seat plumb line and mark the bottom plumb line

as you did in Step 1. You may wish to leave the tails long until all the rafters are in place, so that you can mark the ends to a line and then cut.

NOTE: The top and bottom cuts on the rake board are also done in the same way as a common rafter but the distance from the top cut to the bottom cut is the rake board length.

HIP AND VALLEY RAFTERS

The hip and valley rafters are treated very similarly because both run at a 45° angle to the common rafter, and they both form the diagonal or hypotenuse of a right triangle (see Figure 8). The three sides being the hip, plate and common rafter, or the valley, ridge and common rafter. Therefore, the cuts and lengths apply equally to hip and valley rafters.

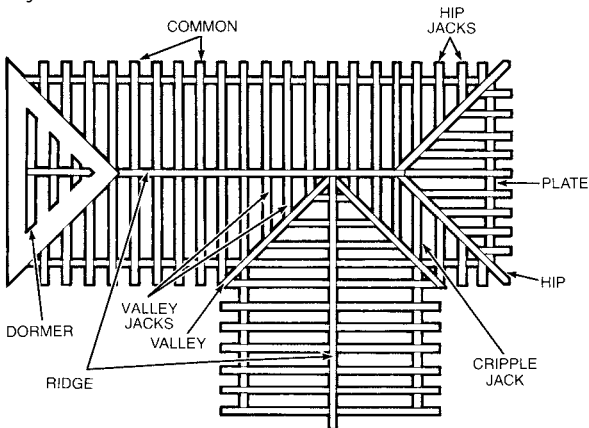

FIG. 8 Top View Rafter Definition.

HIP-VAL LENGTH: Use the table on page 47 to obtain the hip or valley rafter length (continuing the 8 Inch Rise example from page 9, Step 3). In our example an 8 Inch Rise is used, therefore find the column headed “Run Ft.” and locate 13’. To the right read the column headed “Hip or Val. Rafter Length” and find a length of 20’ 3-7/8” (see Figures 8, 9, 10, 12 and 13).

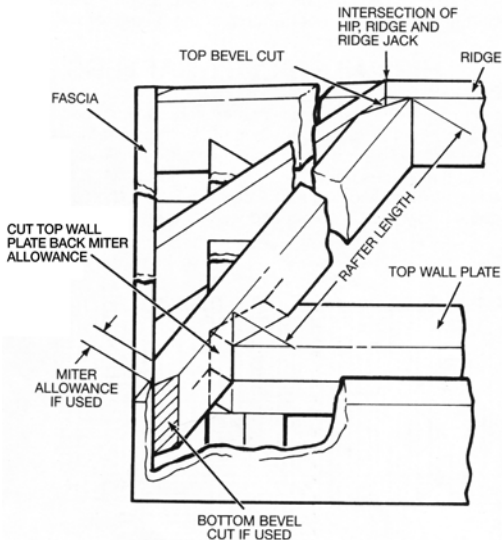

FIG. 9 View of Hip Rafter Layout.

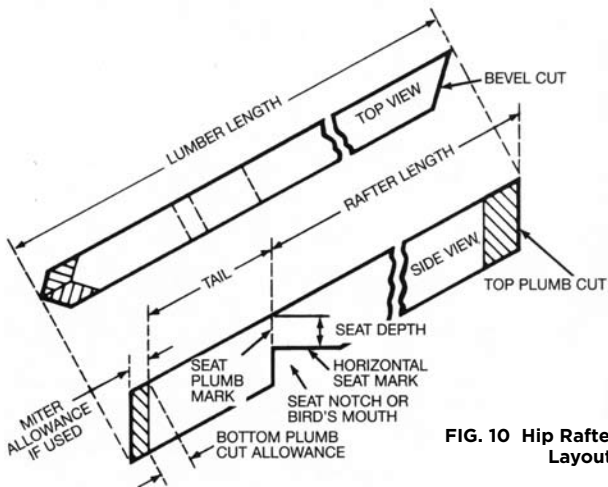

FIG. 10 Hip Rafter Layout.

TAIL OR EAVE LENGTH: Use the same procedure as you did for the common rafter but remember to use the Hip-Val column. Again we have in our example a tail 1' 9" long, thus giving us:

$$\begin{array}{r}
 1' \text{ Run} = 1' 6\text{-}3/4'' \\
 9'' \text{ Run} = 14\text{-}1/8'' \\
 \hline
 1' 9'' \text{ Tail} = 2' 8\text{-}7/8''
 \end{array}$$

NOTE: If a miter is desired, add for hip or val miter allowance from the tables (see Figures 10 and 13).

HIP-VAL LUMBER LENGTH: Add an allowance for a bottom plumb cut and, if used, a miter. Obtaining from the table the allowance for the bottom plumb cut (using a 2 x 6)

and a miter allowance (using a 1 1/2" actual rafter thickness) we get:

RAFTER LENGTH	=	20' 3-7/8"
TAIL LENGTH	=	2' 8-7/8"
BOTTOM PLUMB ALLOW.	=	3-11/16"
MITER ALLOWANCE	=	7/8"
<u>LUMBER LENGTH</u>	=	<u>23' 5-5/16"</u>

NOTE: Only add miter allowances if they are used.

HIP RAFTER LAYOUT

STEP 1. TOP PLUMB CUT: The square is used in the same manner as in Step 1 of the common rafter top plumb cut. But now, read the Inch-Rise on the Hip-Val scale instead. Remember that the top plumb cut is a bevel cut and that opposite rafters will have opposite bevel cuts (see Figures 9 and 10). Therefore when placing the square on the rafter, place it on the long side of the bevel (the bevel cut will be explained in Step 4).

STEP 2. SEAT NOTCH: Measure the rafter length down along the top of the rafter and make the seat plumb mark in the same manner as you did for the common rafter (in our example it is 20' 3-7/8"). Next, measure along the seat plumb mark the seat depth and using the dashed line on the square, draw a perpendicular line for the horizontal seat mark (see Figure 10). Be sure all horizontal cuts for all rafters are the same distance from the top edge of the rafter at the wall line. For the proper fit of the hip rafter, cut the top wall plate corner off (as shown in Figure 9). This allows Hip seat notch to set in against a full flat corner, rather than against an outside point.

STEP 3. TAIL OR BOTTOM PLUMB CUT: Measure down the top of the hip rafter from the seat plumb mark and mark the distance for the tail (in our example 2' 8-7/8"). Using our square, make the bottom plumb mark. If a tail miter is

used, make another plumb mark on the other side of the rafter just opposite of the bottom plumb mark (see Figure 10).

STEP 4. CUTTING HIP RAFTER PATTERN: With your saw set at 45° , cut the top plumb cut, making sure the top bevels are opposite for opposite rafters. Setting the saw at 45° automatically gives the plumb cut and the side cut bevel. Make bottom plumb cut on a 45° angle if miter is used. If a bevel is not needed, set saw at 90° . The seat notch is made with the saw at 90° (see Figures 9 and 10).

INTERSECTION OF HIPS ON RIDGE

To find the intersection points of the hip on the ridge rafter, cut ridge one foot longer at the point where hips intersect the ridge. With a regular length common rafter, set the seat notch cut over the edge of the top plate, in line with the ridge (see Figure 11). Making sure your walls are straight, place top end of common rafter even with top of ridge.

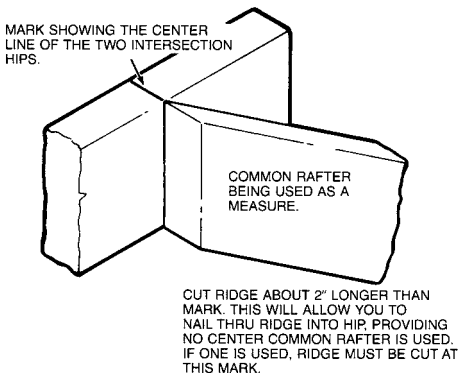

FIG. 11 Intersection of Hips on Ridge.

Now mark across top of ridge (as shown). This mark will be the center of the two intersecting hips. If a common rafter is to be used, the ridge will be cut off at this mark and the common rafter butted up against it (see Figure 9). If no common rafter will be used, cut the ridge about 2" longer. This will allow you to nail through the ridge into the hip.

VALLEY RAFTER LAYOUT

STEP 1. TOP PLUMB CUT: Using the Hip-Val scale again, make the top plumb mark in the usual way. Now measure down the top of the rafter from this mark for a miter allowance, if used (see Figures 12 and 13). Look up the allowance in the Tables under the rise and the rafter thickness that you are using (in our example: 8" rise and 1-1/2" actual rafter thickness, resulting in a 7/8" allowance). Then make two plumb marks on both sides of the rafter for the top plumb bevel cuts.

STEP 2. SEAT NOTCH: From the first top plumb mark, measure down the rafter length (in our example: 20' 3-7/8") and make the seat plumb mark (see Figure 13). Now, go down the rafter from the seat plumb mark the miter allowance distance (found in the table for your inch rise and actual rafter thickness) and make a plumb line for the miter allowance. Draw the same miter plumb line on the other side of the rafter for making the bevel cut. This mitered seat cut will allow the valley rafter to fit down over the crotch formed by the joining wall plates (see Figure 12). Next, to make the horizontal seat mark, measure down to the seat depth on the seat plumb mark (not the miter plumb line). Aligning the dashed line on our square with the seat plumb mark, draw a perpendicular line using the bottom edge of our Square to the edge of the rafter. Also extend the horizontal seat mark to the added miter allowance plumb line (see Figures 7 and 13). Double check to see that all seat notches are the same depth.

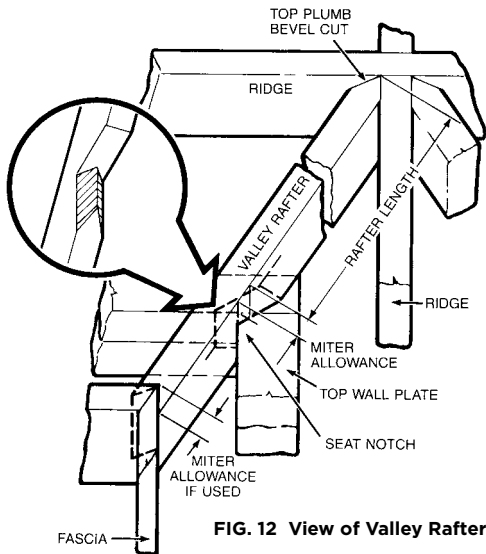
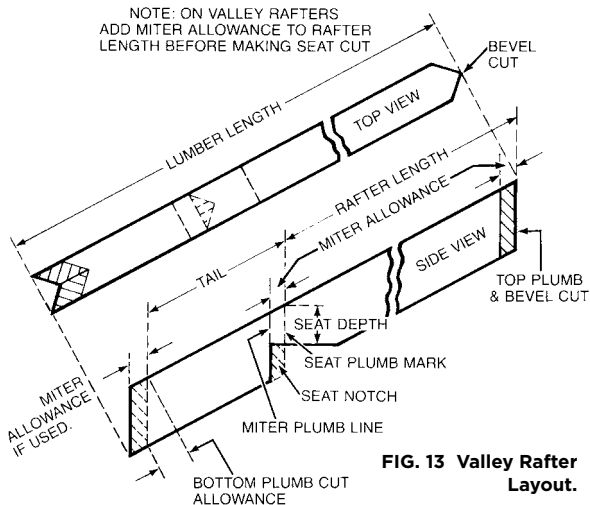

FIG. 12 View of Valley Rafter Layout.

STEP 3. BOTTOM OR TAIL PLUMB CUT: Measure down the top of the valley rafter from the SEAT PLUMB MARK and mark the tail length (in our example: 2' 8-7/8"). Be sure to add the miter allowance in the measurement, if used (see Figure 13). Make the bottom plumb mark with the square in the normal manner.

STEP 4. RAFTER PATTERN CUTS: To make the top and bottom cuts, tilt the saw at 45° (see Figure 13). Also make the seat miter cuts. Now change the saw tilt to 90° for the horizontal seat cut. You may want to check for proper fit and use this rafter as a pattern for the other valley rafters.



JACK RAFTERS

JACK RAFTER LENGTH: The Jack Rafter Tables are different than those for the other rafters. The table lists, in the first column, the varying center-to-center spacing of the jack rafters. Then in the second column is the difference in length from one jack to the next (see Figures 14 and 15). This difference in length is to be added to or subtracted from the rafter length as you progress from jack to jack (using the spacing selected). In our example of a 8" rise, and lets assume a 24" spacing; we have a 2' 4-7/8" difference in length. Therefore, to obtain the length of the first or longest jack rafter, measure the distance from the edge

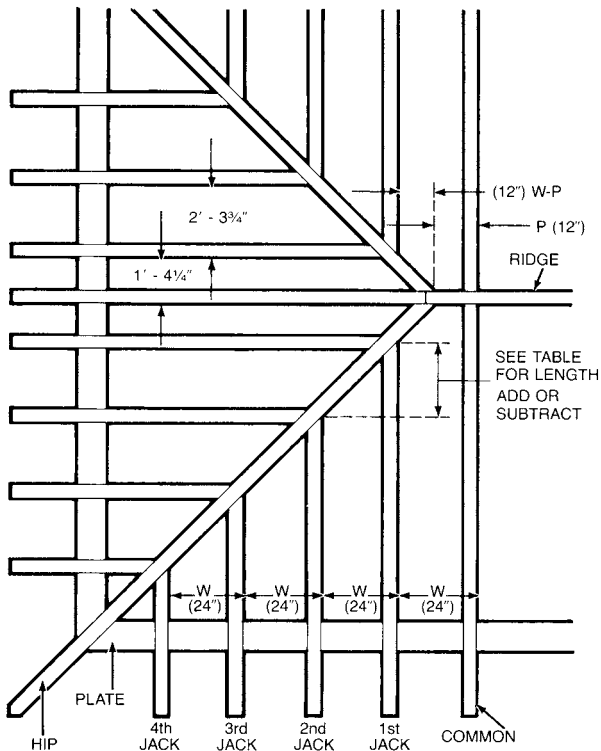

FIG. 14 Top View of Hip Jack Rafter Spacing.

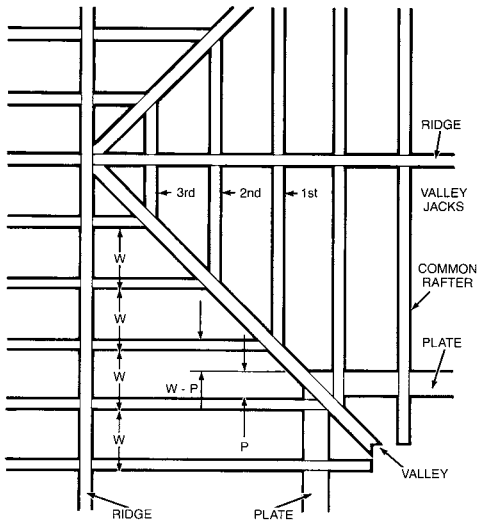

FIG. 15 Top View of Valley Jack Rafter Spacing.

distance from the edge of the last common rafter to the intersection of the hip and ridge, or the valley and top plate (for a valley jack). This measurement is called (P) in Figures 14 and 15. Now subtract the measurement (P) from the spacing you are using (W). The result ($W - P$) is the distance from the intersection of the hip and ridge to the first hip jack or the plate corner to the first valley jack. Look in the table for this distance and find the length to deduct from the common rafter length. In our example again, let us take a measurement of 12" from the common rafter far side edge to where the hip intersects the ridge ($W - P = 24 - 12 = 12$). Therefore:

$$\begin{array}{rcl} \text{COMMON RAFTER LENGTH} & = & 15' 7\text{-}1/2'' \\ \text{SUBTRACT (W - P) FROM TABLE} & = & 1' 2\text{-}3/8'' \\ \hline \text{FIRST HIP JACK RAFTER LENGTH} & = & 14' 5\text{-}1/8'' \end{array}$$

The tail length must now be added to this length. For all remaining jacks, subtract the full spacing (W). Example: finding in the tables the amount to subtract for a spacing of 24", we get:

$$\begin{array}{rcl} \text{FIRST HIP JACK RAFTER LENGTH} & = & 14' 5\text{-}1/8'' \\ \text{SUBTRACT (W) FROM TABLE} & = & 2' 4\text{-}7/8'' \\ \hline \text{SECOND HIP JACK RAFTER LENGTH} & = & 12' 0 1/4'' \end{array}$$

Continue with this process until you get to the last jack rafter (the process is identical for valley rafters). Always remember to measure the jack rafter length on the long side of the rafter because of the bevel.

Cripple jacks (see Figure 8) use the same method as above, but must be beveled at both ends. Therefore, the subtraction for both ends must be made from a common rafter length as if it went from the plate to the ridge. The cripple jack rafters are actually being measured from long point to long point diagonally along the top edge. By measuring diagonally, you will compensate for 1/2 of the hip thickness and 1/2 of the valley thickness.

TAIL OR EAVE LENGTH: The tail or eave length for all hip jack rafters is the same as for common rafters. If desired, use a common rafter for a pattern. Cripple and valley jacks have no tail (See Figures 14 and 15).

LUMBER LENGTH: The lumber length is found by using the same procedure outlined for common rafters, but subtracting for the rafters' position (see above).

JACK RAFTER LAYOUT

JACK RAFTER LAYOUT CUTS: Seat notches and bottom plumb cuts for hip jack rafters are the same as for common rafters.

The common scale on the square is used for all jack rafters. Whenever a jack rafter rests against a hip or valley rafter, mark a plumb cut, and then cut at a 45° along the mark. This will give both the side cut and the plumb cut. Angles should be checked for direction before cuts are made. See Figures 11 and 14 for the center common rafter at the end of the ridge.

DORMER RAFTERS

Sometimes when adding a room or remodeling, it is easier to build a valley on top of the main roof. This saves cutting into the main roof that could cause weakening.

STEP 1. Referring to Figure 1, mark location of valley on roof at 45° to common rafters. Then set long point of bottom end of rafter even with the mark just made at line "A".

STEP 2. PLUMB CUTS ON THE DORMER RAFTER: Using whatever inch rise has been determined, make them the same as the common rafter.

STEP 3. RAFTER LENGTH: Once the shortest rafter is measured, the rafter length may be determined using the same method as with jack rafters.

STEP 4. BOTTOM CUT: The heel or bottom cut is the same as the horizontal cut of the seat notch (see Figure 7). But cut all the way across the rafter (and without making a seat plumb cut). The saw should be tilted at the same angle as the rise of the roof. Thus allowing your horizontal cut to lay flat against the roof. For example, using the common scale with an 8" rise, you will notice that the number 8 lines up at $33\frac{1}{2}^\circ$ on the degree scale. So tilt your saw at $33\frac{1}{2}^\circ$ before making the bottom cut.

DOOR OVERHANG

In Figure 1 is pictured a roof extension that may be found over a doorway. To find the end cut at point "B," hold the square so that the "T" bar is flat against the rafter. Then using the common rafter scale, make a mark next to the inch rise that was used for the main roof. Now draw a line from the mark just made to the pivot point. This is then the cut required for a flat

roof. For a pitched roof, use the angle scale and make your mark next to the angle that is the result of the roof inch rise angle minus the overhang inch rise angle.

DEGREE SCALE

With the degree scale on our square, any angle can be found on a board. Figure 16 shows a couple of examples. To find an obtuse angle, for example 105° , put the pivot point on the mark where the cut is to be made. Lay the square so that the "T" bar is held tight against the board and draw a perpendicular line across the board. Now flop the square on its opposite side (making sure you're using the same pivot point) and pivot the square so the degree scale reads 15° ($105^\circ - 90^\circ$). Scribing a line along the bottom edge of the square now gives you a 105° angle (and also a 75° angle and a 15° angle).

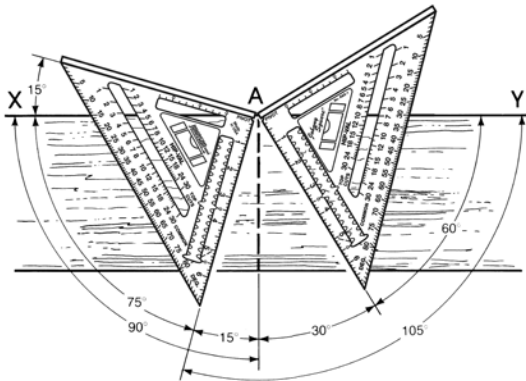

SQUARE SHOWN IN 2 DIFFERENT POSITIONS WITH THE RESULTING ANGLES BEING FOUND BY PIVOTING SQUARE AT POINT (A) ON LINE X-Y.

LAY SQUARE WITH "T" BAR HORIZONTAL ON X-Y LINE TO FIND 90

FIG. 16 Resulting Angles Using the Degree Scale on a Board.

STAIR LAYOUT EXAMPLE

With our square, stair layout can be done simply and efficiently. The layout can be done without hours of calculations. Basic math and the use of a calculator with a square root function are all that are needed.

STEP 1. FIND STEP MEASUREMENTS: We start with the total rise (see Figure 17) to find the number of steps required. If the rise is not known, measure the vertical distance between the lower finished floor and the upper one. Whenever a quantity is known, use it instead of calculating it.

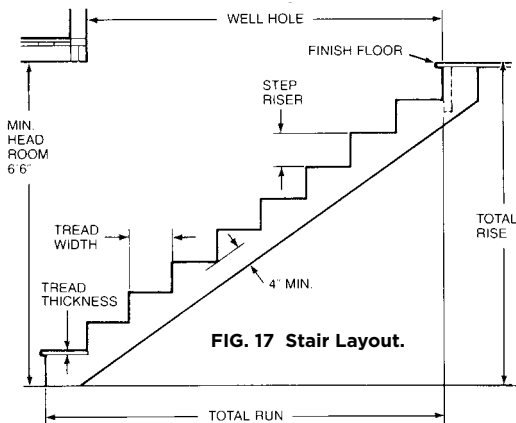

NOTE 1 Before starting your layout, check local and state codes for tread width, length and step rise requirements. Many states have stairway construction regulations.

NOTE 2 It's a good idea to check your layout on paper or cardboard before cutting out the wood steps.

1. Find the approximate number of steps with the following formula:

$$\text{APPROXIMATE NO. OF STEPS} = \frac{\text{TOTAL RISE (inches)}}{7''}$$

For example, let's assume a 8' 6" rise = 102"

$$\begin{aligned} \text{APPROXIMATE NO. OF STEPS} &= \frac{102''}{7''} \\ &= 14.57'' \end{aligned}$$

NOW THE ACTUAL NUMBER OF STEPS WOULD BE THE WHOLE NUMBER, IGNORING ANY FRACTION, i.e., 14 STEPS.

Next, find the actual step rise by using the following computation.

$$\text{ACTUAL STEP RISE} = \frac{\text{TOTAL RISE (inches)}}{\text{NO. OF STEPS}}$$

In our example:

$$\begin{aligned} \text{ACTUAL STEP RISE} &= \frac{102''}{14} \\ &= 7.29'' \end{aligned}$$

2. Now find the step run (or tread width) by subtracting the step rise from 17 1/2":

$$\begin{aligned} \text{STEP RUN} &= 17.5'' - \text{ACTUAL STEP RISE} \\ &= 17.5'' - 7.29'' \\ &= 10.21'' \end{aligned}$$

Thus the total run is:

$$\begin{aligned} \text{TOTAL RUN} &= \text{STEP RUN} \times (\text{NO. OF STEPS} - 1) \\ &= 10.21'' \times (14 - 1) \\ &= 10.21'' \times 13 \\ &= 132.73'' \end{aligned}$$

Finally we calculate the inch rise (similar to the rafter inch rise):

$$\begin{aligned} \text{INCH RISE} &= \frac{\text{ACTUAL STEP RISE (inches)} \times 12}{\text{ACTUAL STEP RUN (inches)}} \\ &= \frac{7.29'' \times 12}{10.21''} \\ &= 8.57'' \end{aligned}$$

The ideal inch rise is 7 or 8 (or 30° to 35°) but may be from a 5-inch rise to a 14-inch rise depending on the circumstances. The step rise or run may be modified if the run becomes impractical or if the minimum head room is under 6 1/2 ft. Check the head room by measuring down along a plumb line dropped from the lowest ceiling point to where the tread beneath would be. To find the tread height, count the number of steps necessary to get under the plumb line and then multiply by the step rise. Another consideration is to have a minimum of 4" from the inside corner of the step to the bottom edge of the stringer (See Figure 18). A quick test is to use the square as you did for the common rafter top plumb cut (using the step inch rise) and make a plumb line the distance of the step rise, then measuring from the end of the plumb line directly to the edge of the stringer.

The tread length depends on available room and intended use. For instance, for two-way traffic a length of 36 to 42 inches is needed, whereas one-way traffic doesn't require over a 24 inch length. Also, the calculated tread width does not include a nosing width (1-3/4" being maximum).

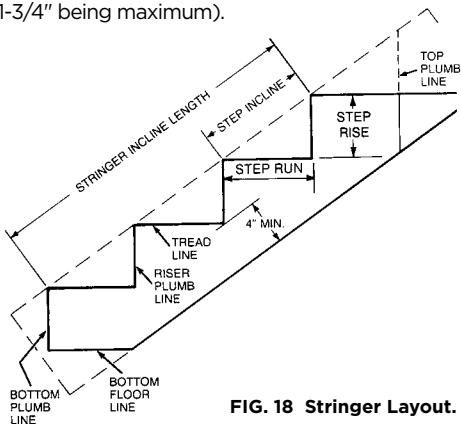

FIG. 18 Stringer Layout.

STEP 2. LAYOUT STRINGER: First, find the step incline length (see Figure 18) by using the following formula:

$$\text{STEP INCLINE} = \sqrt{(\text{STEP RISE})^2 + (\text{STEP RUN})^2}$$

In our example:

$$\text{STEP RISE} = 7.29$$

$$\text{STEP RUN} = 10.21$$

USING THE FOLLOWING INCLINE FORMULA:

$$\begin{aligned}\text{STEP INCLINE} &= \sqrt{(7.29)^2 + (10.21)^2} \\ &= \sqrt{53.14 + 104.24} \\ &= \sqrt{157.38} \\ &= \underline{12.545}\end{aligned}$$

NOTE: The symbol $\sqrt{\quad}$ is the square root symbol.

Second, find the stringer incline length by using the following formula:

$$\begin{aligned}\text{Stringer Incline Length} &= \\ &\text{Step Incline Length} \times (\text{number of steps} - 1)\end{aligned}$$

In our example:

$$\begin{aligned}\text{Stringer Incline Length} &= 12.545 \times (14 - 1) \\ &= 12.545 \times (13) \\ &= 163.085 \text{ Inches} \\ &= 13 \text{ ft. } 7\text{-}1/16 \text{ Inches}\end{aligned}$$

NOTE: Table B on Page 30 shows the inch decimal to inch fraction conversion.

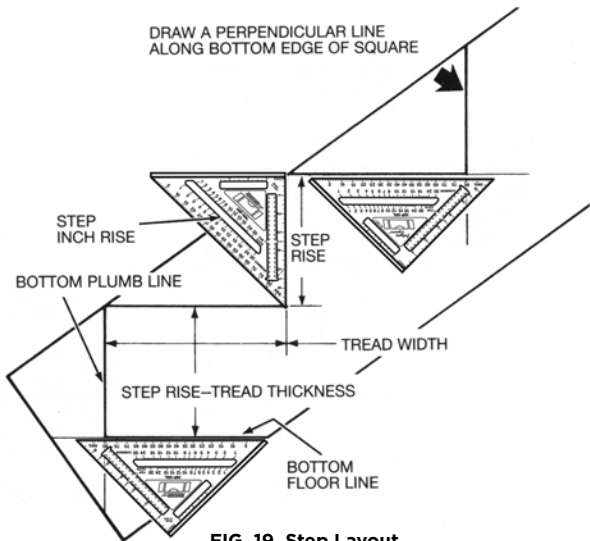

FIG. 19 Step Layout.

Now, draw the bottom plumb line using your inch rise on the common scale of the square, exactly as you did for the common rafter (see Figures 18 and 19). If you wish to conserve wood, adjust the bottom plumb line so that its length is equal to the step rise. Next draw the bottom floor line by measuring down the bottom plumb line the distance of the step rise minus the tread thickness. In our example, with a 1" tread; 7.29" minus 1.00" giving you 6.29", or 6 5/16". Use the square the same way as you did for the bird's mouth horizontal seat mark (See 7A & 7B and 19).

The outside step corners should now be marked off (again see Figure 18). Starting from the bottom plumb line, measure up along the top edge of the stringer the distance of a step incline. Repeat this for each step corner, until you've reached the stringer incline length. Make another step incline mark for a top plumb line.

Now draw the riser plumb lines for all the steps, using the square as you did for the bottom plumb line. Finally, draw a top plumb line. Using the same procedure as you did for the bottom floor line, draw all the step tread lines (see Figure 19). Be sure to measure down the riser plumb line the distance of the step rise only. Make the last tread line which will be the top floor line. If the stringer is to go below the top floor boards, add the floor board thickness to the step rise when measuring down the top plumb line to draw the top floor line (this is to be done when the bottom floor line was found by not taking into account the tread thickness). If the tread thickness was used, add the difference between the floor board thickness and the tread thickness.

STEP 3. CUTTING STRINGER PATTERN: The stringer pattern should be ready to cut, except for any special allowances for anchoring the top of the stringer. Once that is laid out, you may want to clamp both stringers together before cutting to be sure the stringers are identical.

TABLE B

Change Decimals to Fractions

$.06'' = 1/16''$	$.56'' = 9/16''$
$.13'' = 1/8''$	$.63'' = 5/8''$
$.19'' = 3/16''$	$.69'' = 11/16''$
$.25'' = 1/4''$	$.75'' = 3/4''$
$.31'' = 5/16''$	$.81'' = 13/16''$
$.38'' = 3/8''$	$.88'' = 7/8''$
$.44'' = 7/16''$	$.94'' = 15/16''$
$.50'' = 1/2''$	

SOLAR PANEL SUPPORT EXAMPLE

Let us build a rafter support for a series of flat plate collectors on a south-facing 8-inch rise roof.

STEP 1. RAFTER CALCULATIONS: The pitch for the support rafters, which is really the desired tilt angle for the solar panels, will be needed. If known in degrees, convert it to the nearest inch rise so that the tables may be used. This pitch is found by adding 10 to 15 degrees to your latitude (since this is theoretically the best for heating). In our example, we need a 58° pitch or a 19 inch rise because the latitude of Milwaukee is 43° . (See Table C, page 39). The angle of tilt is not critical, since the efficiency is not appreciably reduced by a small difference in tilt angle from optimum, thus the closest inch rise can be used (see Figures 20 and 21).

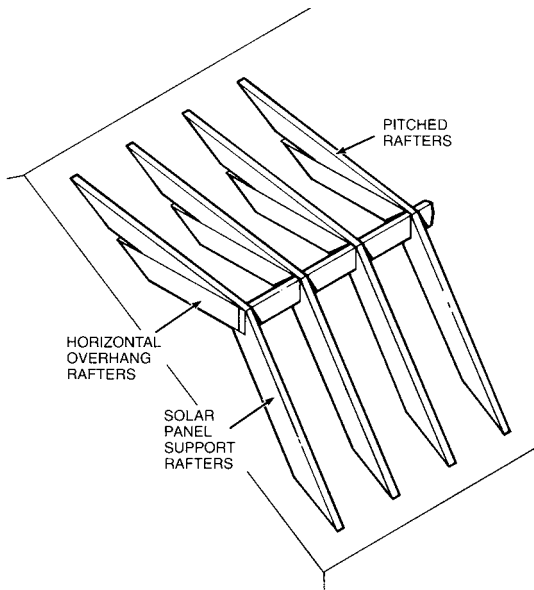

FIG. 20 A Rafter Support Structure for Solar Panels.

Now find the support rafter rise and run by using the tables somewhat in reverse from the way you have done so far. First find the proper table for your support rafter inch rise and locate your length under the common rafter length column (note: you may have to refer to both the Run (ft.) column plus the Run (inch) column in referring to the correct length). In our example we need a 50" or 4' 2"

support rafter length. To begin with, we find a 2' run having a 3' 9" length. This then leaves a 5" length which results in an approximation of a 2-11/16" run. If needed, approximation can be done with the following equation, if desired:

$$R_m = \frac{(R_h \times (\frac{L_m - L_l}{L_h - L_m})) + R_l}{1.00 + (\frac{L_m - L_l}{L_h - L_m})}$$

Where R = run, L = length, l = low, m = middle, h = high.

In our example:

$$R_m = \frac{(3.00 \times (\frac{5.00 - 4.63}{5.63 - 5.00})) + 2.50}{1.00 + (\frac{5.00 - 4.63}{5.63 - 5.00})}$$

$$= 2.69$$

$$= 2-11/16"$$

Thus we have for the support rafter run, 2' plus 2 11/16" equalling 2' 2-11/16" (or 26.69"). Now to find the support rafter rise:

$$\text{SUPPORT RAFTER RISE (in.)} = \frac{\text{Inch Rise} \times \text{Run (in.)}}{12}$$

$$= \frac{19 \text{ inch rise} \times 26.69''}{12}$$

$$= 42.25''$$

Converted to feet:

$$= 3' 6-1/4''$$

Next we need to find the horizontal overhang length (see Figure 21). It is found by finding the roof run between points A and B and then subtracting the support rafter run

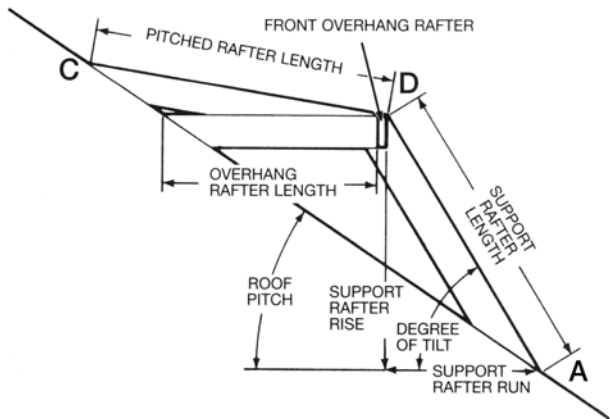

FIG. 21 Rafter Layout For A Solar Panel.

and the front overhang rafter thickness. The roof run between points A and B is found by:

$$\begin{aligned}
 \text{ROOF RUN (in.)} &= \frac{\text{ROOF RISE (in.)} \times 12}{\text{INCH RISE}} \\
 &= \frac{42.25'' \times 12}{8 \text{ inch rise}} \\
 &= 63.37'' \\
 &= 5' 3\text{-}3/8''
 \end{aligned}$$

From this we can get the overhang rafter length, noting that we are using 2 x 6 rafters giving a thickness of 1-1/2":

$$\begin{array}{r} \text{ROOF RUN BETWEEN A \& B} \\ - \text{ SUPPORT RAFTER RUN} \\ - \text{ FRONT OVERHANG THICKNESS} \\ \hline = \text{ OVERHANG RAFTER LENGTH} \\ 63.37'' \\ - 26.69'' \\ - 1.50'' \\ \hline = 35.18'' \\ \text{or in feet:} \qquad \qquad \qquad = 2' 11 \frac{3}{16}'' \end{array}$$

Lastly we need to find the pitched rafter length, the rafter above the horizontal overhang rafter. In our example, the pitched rafter length will equal the support rafter length (i.e., 50").

STEP 2. RAFTER LAYOUTS: The support rafter bottom cut layout (at point A on Figure 21) will be made similar to a pitched door overhang. Drape the square "T" over the top (or outside) edge of the support rafter and hold the square firmly against the rafter. Then make a mark, using the angle scale, next to the angle that is found by subtracting the roof pitch angle (the roof inch rise in degrees) from the support rafter inch rise angle. In our example, we have $57 \frac{3}{4}^\circ$ (for the 19 inch rise support) minus $33 \frac{3}{4}^\circ$ (for the 8 inch rise roof) or 24° . From this mark, draw a line to the pivot point and you will then have the bottom cut layout. The support rafter top cut layout (at point D in Figure 21) is similar to the bird's mouth layout. First measure up the outside of the rafter the rafter length from the bottom cut and then draw a plumb line using the support rafter inch rise. Now, instead of measuring down the seat depth, measure down the overhang rafter width and make a horizontal line going to the roof edge of the rafter.

The horizontal overhang rafter layout is identical to the layout for a flat roof extension (hence its name).

The pitched rafter top cut layout (at point C in Figure 21) is the same as the support rafter bottom cut layout (at point A). For the pitched rafter bottom cut layout (at point D) the following equation is used:

$$\text{BOTTOM ANGLE} = \text{SUPPORT ANGLE} + (2 \times \text{ROOF ANGLE}) - 90^\circ$$

In our example:

$$\begin{aligned} &= 57 \frac{3}{4}^\circ + (2 \times 33 \frac{3}{4}^\circ) - 90^\circ \\ &= 35 \frac{1}{4}^\circ \end{aligned}$$

Use this equation when the pitched rafter length equals the support rafter length. We then hold the square tight against the top edge of the rafter as we did for the top cut and make a mark at the bottom cut angle (e.g., at $35 \frac{1}{4}^\circ$). A line from this mark to the pivot point gives us the necessary bottom cut pattern.

STEP 3. RAFTER PATTERN CUTS: If Figures 20 and 21 are carefully studied, the rafter pattern cuts can be easily made following the patterns that were laid out. Set your saw at 90° for all the cuts.

TABLE C

Latitudes for Selected Cities

City, State	Latitude N°	City, State	Latitude N°
Atlanta, GA	34	Lincoln, NE	41
Bismarck, ND	47	Medford, OR	42
Boston, MA	42	Milwaukee, WI	43
Brownsville, TX	26	Nashville, TN	36
Caribou, ME	47	Oklahoma City, OK	35
Columbus, OH	40	Raleigh, NC	36
Fresno, CA	37	Salt Lake City, UT	41
Indianapolis, IN	40	Tallahassee, FL	30
Las Vegas, NV	36	Toronto, Canada	44

1 INCH RISE 4 3/4 DEGREES

Run Ft.	Common Rafter Length	Hip or Val. Rafter Length
1	1' 0 1/8"	1' 5"
2	2' 0 1/8"	2' 10"
3	3' 0 1/8"	4' 3"
4	4' 0 1/4"	5' 8"
5	5' 0 3/4"	7' 1"
6	6' 0 1/4"	8' 6"
7	7' 0 3/8"	9' 11"
8	8' 0 3/8"	11' 4"
9	9' 0 3/8"	12' 9"
10	10' 0 1/2"	14' 2"
11	11' 0 1/2"	15' 7"
12	12' 0 1/2"	17' 0"
13	13' 0 5/8"	18' 5"
14	14' 0 3/8"	19' 10"
15	15' 0 3/8"	21' 3"
16	16' 0 3/8"	22' 8"
17	17' 0 3/8"	24' 1"
18	18' 0 3/4"	25' 6"
19	19' 0 3/4"	26' 11"
20	20' 0 1/2"	28' 4"
21	21' 0 1/8"	29' 9"
22	22' 0 1/8"	31' 2"
23	23' 1"	32' 7"
24	24' 1"	34' 0"
25	25' 1"	35' 5"

Run In.	Common Rafter Length	Hip or Val. Rafter Length
1/2	1/2"	3/4"
1	1"	1 3/8"
1 1/2	1 1/2"	2 1/8"
2	2"	2 7/8"
2 1/2	2 1/2"	3 1/2"
3	3"	4 1/4"
3 1/2	3 1/2"	5"
4	4"	5 5/8"
4 1/2	4 1/2"	6 3/8"
5	5"	7 1/8"
5 1/2	5 1/2"	7 3/4"
6	6"	8 1/2"
6 1/2	6 1/2"	9 1/4"
7	7"	9 5/8"
7 1/2	7 1/2"	10 5/8"
8	8"	11 3/8"
8 1/2	8 1/2"	12"
9	9"	12 3/4"
9 1/2	9 1/2"	13 1/2"
10	10"	14 1/8"
10 1/2	10 1/2"	14 7/8"
11	11"	15 5/8"
11 1/2	11 1/2"	16 1/4"

Spacing In.	Jack Rafter Length
1	1"
2	2"
3	3"
4	4"
5	5"
6	6"
7	7"
8	8"
9	9"
10	10"
11	11"
12	1' 0"
13	1' 1"
14	1' 2"
15	1' 3"
16	1' 4"
17	1' 5"
18	1' 6 1/8"
19	1' 7 1/8"
20	1' 8 1/8"
21	1' 9 1/8"
22	1' 10 1/8"
23	1' 11 1/8"
24	2' 0 1/8"

Rafter Thickness	Miter Allowance for Hip and Valley Rafters	Rafter Depth	Bottom Allowance
1 1/2"	3/4"	3 1/2"	5/16"
1 5/8"	13/16"	5 1/2"	7/16"
1 3/4"	7/8"	7 1/4"	5/8"
1 7/8"	15/16"	9 1/4"	3/4"

2 INCH RISE 9 1/2 DEGREES

Run Ft.	Common Rafter Length	Hip or Val. Rafter Length
1	1' 0 1/2"	1' 5 1/8"
2	2' 0 3/8"	2' 10 1/4"
3	3' 0 1/2"	4' 3 1/4"
4	4' 0 5/8"	5' 8 3/8"
5	5' 0 7/8"	7' 1 1/2"
6	6' 1"	8' 6 1/2"
7	7' 1 1/8"	9' 11 3/8"
8	8' 1 3/8"	11' 4 3/4"
9	9' 1 1/2"	12' 9 3/4"
10	10' 1 5/8"	14' 2 1/8"
11	11' 1 7/8"	15' 8"
12	12' 2"	17' 1 1/8"
13	13' 2 1/8"	18' 6 1/8"
14	14' 2 3/8"	19' 11 1/4"
15	15' 2 1/2"	21' 4 3/8"
16	16' 2 5/8"	22' 9 3/8"
17	17' 2 7/8"	24' 2 1/2"
18	18' 3"	25' 7 3/8"
19	19' 3 1/8"	27' 0 3/4"
20	20' 3 3/8"	28' 5 3/4"
21	21' 3 1/2"	29' 10 3/8"
22	22' 3 5/8"	31' 4"
23	23' 3 7/8"	32' 9"
24	24' 4"	34' 2 1/8"
25	25' 4 1/8"	35' 7 1/4"

Run In.	Common Rafter Length	Hip or Val. Rafter Length
1/2	1/2"	3/4"
1	1"	1 3/8"
1 1/2	1 1/2"	2 1/8"
2	2"	2 7/8"
2 1/2	2 1/2"	3 1/2"
3	3"	4 1/4"
3 1/2	3 1/2"	5"
4	4"	5 3/4"
4 1/2	4 1/2"	6 3/8"
5	5"	7 1/8"
5 1/2	5 1/2"	7 7/8"
6	6"	8 1/2"
6 1/2	6 1/2"	9 1/4"
7	7"	10"
7 1/2	7 1/2"	10 5/8"
8	8"	11 3/8"
8 1/2	8 1/2"	12 1/8"
9	9"	12 7/8"
9 1/2	9 1/2"	13 1/2"
10	10"	14 1/4"
10 1/2	10 1/2"	15"
11	11"	15 5/8"
11 1/2	11 1/2"	16 3/8"

Spacing In.	Jack Rafter Length
1	1"
2	2"
3	3"
4	4"
5	5 1/8"
6	6 1/8"
7	7 1/8"
8	8 1/8"
9	9 1/8"
10	10 1/8"
11	11 1/8"
12	1' 0 1/8"
13	1' 1 1/8"
14	1' 2 1/4"
15	1' 3 1/4"
16	1' 4 1/4"
17	1' 5 1/4"
18	1' 6 1/4"
19	1' 7 1/4"
20	1' 8 1/4"
21	1' 9 1/4"
22	1' 10 1/4"
23	1' 11 3/8"
24	2' 0 3/8"

Rafter Thickness	Miter Allowance for Hip and Valley Rafters	Rafter Depth	Bottom Allowance
1 1/2"	3/4"	3 1/2"	9/16"
1 5/8"	13/16"	5 1/2"	15/16"
1 3/4"	7/8"	7 1/4"	13/16"
1 7/8"	15/16"	9 1/4"	19/16"

3 INCH RISE

3-12 PITCH 14 DEGREES

Run Ft.	Common Rafter Length	Hip or Val. Rafter Length
1	1' 0 $\frac{3}{8}$ "	1' 5 $\frac{1}{4}$ "
2	2' 0 $\frac{3}{4}$ "	2' 10 $\frac{1}{4}$ "
3	3' 1 $\frac{1}{8}$ "	4' 3 $\frac{3}{4}$ "
4	4' 1 $\frac{1}{2}$ "	5' 9"
5	5' 1 $\frac{7}{8}$ "	7' 2 $\frac{1}{8}$ "
6	6' 2 $\frac{1}{4}$ "	8' 7 $\frac{3}{8}$ "
7	7' 2 $\frac{5}{8}$ "	10' 0 $\frac{5}{8}$ "
8	8' 3"	11' 5 $\frac{1}{8}$ "
9	9' 3 $\frac{3}{8}$ "	12' 11 $\frac{1}{8}$ "
10	10' 3 $\frac{3}{4}$ "	14' 4 $\frac{3}{8}$ "
11	11' 4 $\frac{1}{8}$ "	15' 9 $\frac{5}{8}$ "
12	12' 4 $\frac{1}{2}$ "	17' 2 $\frac{1}{8}$ "
13	13' 4 $\frac{7}{8}$ "	18' 8"
14	14' 5 $\frac{1}{4}$ "	20' 1 $\frac{1}{4}$ "
15	15' 5 $\frac{1}{2}$ "	21' 6 $\frac{1}{2}$ "
16	16' 5 $\frac{3}{8}$ "	22' 11 $\frac{3}{4}$ "
17	17' 6 $\frac{1}{4}$ "	24' 5"
18	18' 6 $\frac{3}{8}$ "	25' 10 $\frac{1}{4}$ "
19	19' 7"	27' 3 $\frac{1}{2}$ "
20	20' 7 $\frac{3}{8}$ "	28' 8 $\frac{3}{4}$ "
21	21' 7 $\frac{3}{4}$ "	30' 1 $\frac{7}{8}$ "
22	22' 8 $\frac{1}{8}$ "	31' 7 $\frac{1}{8}$ "
23	23' 8 $\frac{1}{2}$ "	33' 0 $\frac{5}{8}$ "
24	24' 8 $\frac{3}{8}$ "	34' 5 $\frac{3}{8}$ "
25	25' 9 $\frac{1}{4}$ "	35' 10 $\frac{7}{8}$ "

Run In.	Common Rafter Length	Hip or Val. Rafter Length
$\frac{1}{2}$	$\frac{1}{2}$ "	$\frac{3}{4}$ "
1	1"	1 $\frac{3}{8}$ "
1 $\frac{1}{2}$	1 $\frac{1}{2}$ "	2 $\frac{1}{8}$ "
2	2"	2 $\frac{5}{8}$ "
2 $\frac{1}{2}$	2 $\frac{5}{8}$ "	3 $\frac{1}{2}$ "
3	3 $\frac{1}{8}$ "	4 $\frac{1}{4}$ "
3 $\frac{1}{2}$	3 $\frac{5}{8}$ "	5"
4	4 $\frac{1}{8}$ "	5 $\frac{3}{4}$ "
4 $\frac{1}{2}$	4 $\frac{5}{8}$ "	6 $\frac{1}{2}$ "
5	5 $\frac{1}{8}$ "	7 $\frac{1}{8}$ "
5 $\frac{1}{2}$	5 $\frac{5}{8}$ "	7 $\frac{5}{8}$ "
6	6 $\frac{1}{8}$ "	8 $\frac{3}{8}$ "
6 $\frac{1}{2}$	6 $\frac{3}{4}$ "	9 $\frac{3}{8}$ "
7	7 $\frac{1}{4}$ "	10"
7 $\frac{1}{2}$	7 $\frac{3}{4}$ "	10 $\frac{3}{4}$ "
8	8 $\frac{1}{4}$ "	11 $\frac{1}{2}$ "
8 $\frac{1}{2}$	8 $\frac{3}{4}$ "	12 $\frac{1}{4}$ "
9	9 $\frac{1}{4}$ "	12 $\frac{1}{2}$ "
9 $\frac{1}{2}$	9 $\frac{3}{4}$ "	13 $\frac{3}{8}$ "
10	10 $\frac{1}{4}$ "	14 $\frac{3}{8}$ "
10 $\frac{1}{2}$	10 $\frac{3}{8}$ "	15 $\frac{1}{8}$ "
11	11 $\frac{3}{8}$ "	15 $\frac{3}{4}$ "
11 $\frac{1}{2}$	11 $\frac{7}{8}$ "	16 $\frac{1}{2}$ "

Spacing In.	Jack Rafter Length
1	1"
2	2"
3	3 $\frac{1}{8}$ "
4	4 $\frac{1}{8}$ "
5	5 $\frac{1}{8}$ "
6	6 $\frac{1}{8}$ "
7	7 $\frac{1}{8}$ "
8	8 $\frac{1}{4}$ "
9	9 $\frac{1}{4}$ "
10	10 $\frac{1}{4}$ "
11	11 $\frac{3}{8}$ "
12	1' 0 $\frac{3}{8}$ "
13	1' 1 $\frac{3}{8}$ "
14	1' 2 $\frac{1}{8}$ "
15	1' 3 $\frac{1}{2}$ "
16	1' 4 $\frac{1}{2}$ "
17	1' 5 $\frac{1}{2}$ "
18	1' 6 $\frac{1}{2}$ "
19	1' 7 $\frac{3}{8}$ "
20	1' 8 $\frac{3}{8}$ "
21	1' 9 $\frac{5}{8}$ "
22	1' 10 $\frac{5}{8}$ "
23	1' 11 $\frac{3}{4}$ "
24	2' 0 $\frac{3}{4}$ "

Rafter Thickness	Miter Allowance for Hip and Valley Rafters	Rafter Depth	Bottom Allowance
1 $\frac{1}{2}$ "	$\frac{3}{4}$ "	3 $\frac{1}{2}$ "	$\frac{7}{8}$ "
1 $\frac{5}{8}$ "	$\frac{13}{16}$ "	5 $\frac{1}{2}$ "	1 $\frac{3}{8}$ "
1 $\frac{3}{4}$ "	$\frac{7}{8}$ "	7 $\frac{1}{4}$ "	1 $\frac{13}{16}$ "
1 $\frac{7}{8}$ "	$\frac{15}{16}$ "	9 $\frac{1}{4}$ "	2 $\frac{5}{16}$ "

4 INCH RISE

4-12 PITCH 18½ DEGREES

Run Ft.	Common Rafter Length	Hip or Val. Rafter Length
1	1' 0 ⁵ / ₈ "	1' 5 ¹ / ₂ "
2	2' 1 ³ / ₈ "	2' 10 ⁷ / ₈ "
3	3' 2"	4' 4 ³ / ₈ "
4	4' 2 ⁵ / ₈ "	5' 9 ³ / ₄ "
5	5' 3 ¹ / ₄ "	7' 3 ¹ / ₄ "
6	6' 3 ³ / ₈ "	8' 8 ⁵ / ₈ "
7	7' 4 ⁵ / ₈ "	10' 2 ¹ / ₈ "
8	8' 5 ¹ / ₄ "	11' 7 ¹ / ₂ "
9	9' 5 ³ / ₈ "	13' 1"
10	10' 6 ¹ / ₂ "	14' 6 ³ / ₈ "
11	11' 7 ¹ / ₈ "	15' 1 ¹ / ₄ "
12	12' 7 ³ / ₄ "	17' 5 ¹ / ₄ "
13	13' 8 ¹ / ₂ "	18' 10 ⁵ / ₈ "
14	14' 9 ¹ / ₈ "	20' 4 ¹ / ₈ "
15	15' 9 ³ / ₄ "	21' 9 ¹ / ₂ "
16	16' 10 ³ / ₈ "	23' 3"
17	17' 11"	24' 8 ³ / ₈ "
18	18' 11 ³ / ₄ "	26' 1 ¹ / ₄ "
19	20' 0 ³ / ₈ "	27' 7 ¹ / ₄ "
20	21' 1"	29' 0 ³ / ₄ "
21	22' 1 ⁵ / ₈ "	30' 6 ⁵ / ₈ "
22	23' 2 ¹ / ₄ "	31' 1 ¹ / ₈ "
23	24' 3"	33' 5"
24	25' 3 ⁵ / ₈ "	34' 10 ¹ / ₂ "
25	26' 4 ¹ / ₄ "	36' 3 ⁵ / ₈ "

Run In.	Common Rafter Length	Hip or Val. Rafter Length
¹ / ₂	¹ / ₂ "	³ / ₄ "
1	1"	1 ¹ / ₂ "
1 ¹ / ₂	1 ⁵ / ₈ "	2 ¹ / ₈ "
2	2 ¹ / ₈ "	2 ⁷ / ₈ "
2 ¹ / ₂	2 ³ / ₈ "	3 ⁵ / ₈ "
3	3 ¹ / ₈ "	4 ³ / ₈ "
3 ¹ / ₂	3 ³ / ₄ "	5 ¹ / ₈ "
4	4 ¹ / ₄ "	5 ³ / ₄ "
4 ¹ / ₂	4 ³ / ₄ "	6 ¹ / ₂ "
5	5 ¹ / ₄ "	7 ¹ / ₄ "
5 ¹ / ₂	5 ³ / ₄ "	8"
6	6 ³ / ₈ "	8 ³ / ₄ "
6 ¹ / ₂	6 ⁷ / ₈ "	9 ¹ / ₂ "
7	7 ³ / ₈ "	10 ¹ / ₄ "
7 ¹ / ₂	8"	10 ³ / ₈ "
8	8 ¹ / ₂ "	11 ¹ / ₈ "
8 ¹ / ₂	9"	12 ³ / ₈ "
9	9 ¹ / ₂ "	13 ³ / ₈ "
9 ¹ / ₂	10 ¹ / ₈ "	13 ⁷ / ₈ "
10	10 ⁵ / ₈ "	14 ¹ / ₂ "
10 ¹ / ₂	11 ¹ / ₈ "	15 ¹ / ₄ "
11	11 ⁵ / ₈ "	16"
11 ¹ / ₂	12 ¹ / ₈ "	16 ³ / ₄ "

Spacing In.	Jack Rafter Length
1	1"
2	2 ¹ / ₈ "
3	3 ¹ / ₈ "
4	4 ¹ / ₄ "
5	5 ¹ / ₄ "
6	6 ³ / ₈ "
7	7 ³ / ₈ "
8	8 ³ / ₈ "
9	9 ¹ / ₂ "
10	10 ¹ / ₂ "
11	11 ³ / ₈ "
12	1' 0 ⁵ / ₈ "
13	1' 1 ¹ / ₄ "
14	1' 2 ¹ / ₄ "
15	1' 3 ¹ / ₄ "
16	1' 4 ¹ / ₈ "
17	1' 5 ¹ / ₈ "
18	1' 7"
19	1' 8"
20	1' 9 ¹ / ₈ "
21	1' 10 ¹ / ₈ "
22	1' 11 ¹ / ₄ "
23	2' 0 ¹ / ₄ "
24	2' 1 ¹ / ₄ "

Rafter Thickness	Miter Allowance for Hip and Valley Rafters	Rafter Depth	Bottom Allowance
1 ¹ / ₂ "	13 ¹ / ₁₆ "	3 ¹ / ₂ "	13 ¹ / ₁₆ "
1 ⁵ / ₈ "	7 ⁷ / ₈ "	5 ¹ / ₂ "	11 ³ / ₁₆ "
1 ³ / ₄ "	15 ¹ / ₁₆ "	7 ¹ / ₄ "	2 ⁷ / ₁₆ "
1 ⁷ / ₈ "	1"	9 ¹ / ₄ "	3 ¹ / ₁₆ "

5 INCH RISE 5-12 PITCH 22½ DEGREES

Run Ft.	Common Rafter Length	Hip or Val. Rafter Length
1	1' 1"	1' 5¼"
2	2' 2"	2' 11⅜"
3	3' 3"	4' 5⅞"
4	4' 4"	5' 10¾"
5	5' 5"	7' 4⅞"
6	6' 6"	8' 10⅞"
7	7' 7"	10' 3⅞"
8	8' 8"	11' 9½"
9	9' 9"	13' 3¼"
10	10' 10"	14' 8⅞"
11	11' 11"	16' 2⅝"
12	13' 0"	17' 8⅞"
13	14' 1"	19' 2"
14	15' 2"	20' 7⅝"
15	16' 3"	22' 1⅞"
16	17' 4"	23' 7⅞"
17	18' 5"	25' 0¼"
18	19' 6"	26' 6⅞"
19	20' 7"	28' 0⅞"
20	21' 8"	29' 5⅞"
21	22' 9"	30' 11½"
22	23' 10"	32' 5¼"
23	24' 11"	33' 10⅞"
24	26' 0"	35' 4⅞"
25	27' 1"	36' 10⅞"

Run In.	Common Rafter Length	Hip or Val. Rafter Length
½	½"	¾"
1	1⅞"	1½"
1½	1⅞"	2¼"
2	2⅞"	3"
2½	2¾"	3⅞"
3	3¼"	4⅞"
3½	3¾"	5⅞"
4	4⅞"	5⅞"
4½	4⅞"	6⅞"
5	5⅞"	7⅞"
5½	6"	8⅞"
6	6½"	8⅞"
6½	7"	9⅞"
7	7⅞"	10⅞"
7½	8⅞"	11⅞"
8	8⅞"	11⅞"
8½	9¼"	12½"
9	9¼"	13¼"
9½	10¼"	14"
10	10⅞"	14¾"
10½	11⅞"	15½"
11	11⅞"	16¼"
11½	12½"	17"

Spacing In.	Jack Rafter Length
1	1⅞"
2	2⅞"
3	3¼"
4	4⅞"
5	5⅞"
6	6⅞"
7	7⅞"
8	8⅞"
9	9⅞"
10	10⅞"
11	11⅞"
12	1' 1"
13	1' 2⅞"
14	1' 3⅞"
15	1' 4¼"
16	1' 5⅞"
17	1' 6⅞"
18	1' 7½"
19	1' 8⅞"
20	1' 9⅞"
21	1' 10¾"
22	1' 11⅞"
23	2' 0⅞"
24	2' 2"

Rafter Thickness	Miter Allowance for Hip and Valley Rafters	Rafter Depth	Bottom Allowance
1½"	13/16"	3½"	17/16"
1⅝"	7/8"	5½"	25/16"
1¾"	15/16"	7¼"	3"
1⅞"	1"	9¼"	37/8"

6 INCH RISE 6-12 PITCH 26½ DEGREES

Run Ft.	Common Rafter Length	Hip or Val. Rafter Length
1	1' 1¾"	1' 6"
2	2' 2⅝"	3' 0"
3	3' 4¼"	4' 6"
4	4' 5⅝"	6' 0"
5	5' 7⅞"	7' 6"
6	6' 8½"	9' 0"
7	7' 9⅝"	10' 6"
8	8' 11⅜"	12' 0"
9	10' 0¾"	13' 6"
10	11' 2⅞"	15' 0"
11	12' 3⅝"	16' 6"
12	13' 5"	18' 0"
13	14' 6⅝"	19' 6"
14	15' 7⅞"	21' 0"
15	16' 9¼"	22' 6"
16	17' 10⅝"	24' 0"
17	19' 0⅝"	25' 6"
18	20' 1½"	27' 0"
19	21' 2⅞"	28' 6"
20	22' 4⅝"	30' 0"
21	23' 5⅝"	31' 6"
22	24' 7⅞"	33' 0"
23	25' 8⅝"	34' 6"
24	26' 10"	36' 0"
25	27' 11⅝"	37' 6"

Run In.	Common Rafter Length	Hip or Val. Rafter Length
½	½"	¾"
1	1⅞"	1½"
1½	1⅝"	2¼"
2	2¼"	3"
2½	2¾"	3¾"
3	3⅝"	4½"
3½	3⅞"	5¼"
4	4½"	6"
4½	5"	6¾"
5	5⅝"	7½"
5½	6⅞"	8¼"
6	6¾"	9"
6½	7¼"	9¾"
7	7⅞"	10½"
7½	8⅝"	11¼"
8	9"	12"
8½	9½"	12¾"
9	10⅞"	13½"
9½	10⅝"	14¼"
10	11¼"	15"
10½	11¾"	15¾"
11	12⅝"	16½"
11½	12⅞"	17¼"

Spacing In.	Jack Rafter Length
1	1⅞"
2	2⅞"
3	3⅝"
4	4½"
5	5⅝"
6	6¾"
7	7⅞"
8	9"
9	10⅞"
10	11⅞"
11	1' 0¼"
12	1' 1⅝"
13	1' 2½"
14	1' 3⅝"
15	1' 4¾"
16	1' 5⅝"
17	1' 7"
18	1' 8⅞"
19	1' 9¼"
20	1' 10⅝"
21	1' 11½"
22	2' 0⅝"
23	2' 1¾"
24	2' 2⅞"

Rafter Thickness	Miter Allowance for Hip and Valley Rafters	Rafter Depth	Bottom Allowance
1½"	13/16"	3½"	1¾"
15/8"	15/16"	5½"	2¾"
1¾"	1"	7¼"	3⅝"
17/8"	1⅛"	9¼"	4⅝"

7 INCH RISE

7-12 PITCH 30 1/4 DEGREES

Run Ft.	Common Rafter Length	Hip or Val. Rafter Length
1	1' 1 1/8"	1' 6 3/8"
2	2' 3 3/4"	3' 0 3/4"
3	3' 5 3/4"	4' 7 1/8"
4	4' 7 5/8"	6' 1 1/2"
5	5' 9 1/2"	7' 7 3/4"
6	6' 11 3/8"	9' 2 1/8"
7	8' 1 1/4"	10' 8 1/2"
8	9' 3 3/8"	12' 2 1/8"
9	10' 5"	13' 9 1/4"
10	11' 7"	15' 3 3/8"
11	12' 8 7/8"	16' 10"
12	13' 10 3/4"	18' 4 1/4"
13	15' 0 5/8"	19' 10 3/8"
14	16' 2 1/2"	21' 5"
15	17' 4 3/8"	22' 11 3/8"
16	18' 6 1/4"	24' 5 3/4"
17	19' 8 1/4"	26' 0 1/8"
18	20' 10 1/8"	27' 6 1/2"
19	22' 0"	29' 0 3/4"
20	23' 1 1/8"	30' 7 1/8"
21	24' 3 3/4"	32' 1 1/2"
22	25' 5 5/8"	33' 7 7/8"
23	26' 7 1/2"	35' 2 1/4"
24	27' 9 3/8"	36' 8 5/8"
25	28' 11 3/8"	38' 3"

Run In.	Common Rafter Length	Hip or Val. Rafter Length
1/2	5/8"	3/4"
1	1 1/8"	1 1/2"
1 1/2	1 3/4"	2 1/4"
2	2 1/8"	3"
2 1/2	2 7/8"	3 5/8"
3	3 1/2"	4 5/8"
3 1/2	4"	5 3/8"
4	4 5/8"	6 1/8"
4 1/2	5 1/4"	6 5/8"
5	5 3/4"	7 5/8"
5 1/2	6 3/8"	8 5/8"
6	6 7/8"	9 5/8"
6 1/2	7 1/2"	10"
7	8 1/8"	10 3/4"
7 1/2	8 5/8"	11 1/2"
8	9 1/4"	12 1/4"
8 1/2	9 7/8"	13"
9	10 3/8"	13 3/4"
9 1/2	11"	14 1/2"
10	11 5/8"	15 1/4"
10 1/2	12 1/8"	16 1/8"
11	12 3/4"	16 7/8"
11 1/2	13 3/8"	17 5/8"

Spacing In.	Jack Rafter Length
1	1 1/8"
2	2 3/8"
3	3 1/2"
4	4 5/8"
5	5 3/4"
6	7"
7	8 1/8"
8	9 1/4"
9	10 3/8"
10	11 5/8"
11	1' 0 3/4"
12	1' 1 1/8"
13	1' 3"
14	1' 4 1/4"
15	1' 5 3/8"
16	1' 6 1/2"
17	1' 7 3/8"
18	1' 8 1/8"
19	1' 10"
20	1' 11 1/8"
21	2' 0 1/4"
22	2' 1 1/2"
23	2' 2 5/8"
24	2' 3 3/4"

Rafter Thickness	Miter Allowance for Hip and Valley Rafters	Rafter Depth	Bottom Allowance
1 1/2"	7/8"	3 1/2"	2 1/16"
1 5/8"	15/16"	5 1/2"	3 3/16"
1 3/4"	1"	7 1/4"	4 1/4"
1 7/8"	1 1/16"	9 1/4"	5 3/8"

8 INCH RISE 8-12 PITCH 33 3/4 DEGREES

Run Ft.	Common Rafter Length	Hip or Val. Rafter Length
1	1' 2 1/2"	1' 6 3/4"
2	2' 4 1/8"	3' 1 1/2"
3	3' 7 1/4"	4' 8 1/4"
4	4' 9 3/4"	6' 3 1/8"
5	6' 0 1/8"	7' 9 7/8"
6	7' 2 1/2"	9' 4 3/8"
7	8' 5"	10' 11 3/8"
8	9' 7 3/8"	12' 6 1/8"
9	10' 9 7/8"	14' 0 7/8"
10	12' 0 1/4"	15' 7 7/8"
11	13' 2 5/8"	17' 2 3/8"
12	14' 5 1/8"	18' 9 1/8"
13	15' 7 1/2"	20' 3 1/8"
14	16' 9 7/8"	21' 10 3/8"
15	18' 0 3/8"	23' 5 1/2"
16	19' 2 3/4"	25' 0 1/4"
17	20' 5 1/4"	26' 7"
18	21' 7 5/8"	28' 1 3/4"
19	22' 10"	29' 8 1/2"
20	24' 0 1/2"	31' 3 1/4"
21	25' 2 1/8"	32' 10"
22	26' 5 1/4"	34' 4 3/4"
23	27' 7 3/4"	35' 11 1/2"
24	28' 10 1/8"	37' 6 1/4"
25	30' 0 5/8"	39' 1"

Run In.	Common Rafter Length	Hip or Val. Rafter Length
1/2	5/8"	3/4"
1	1 1/4"	1 5/8"
1 1/2	1 3/4"	2 2/8"
2	2 3/8"	3 3/8"
2 1/2	3"	3 7/8"
3	3 5/8"	4 3/4"
3 1/2	4 1/4"	5 1/2"
4	4 3/4"	6 1/4"
4 1/2	5 3/8"	7"
5	6"	7 7/8"
5 1/2	6 5/8"	8 3/8"
6	7 1/4"	9 3/8"
6 1/2	7 7/8"	10 1/8"
7	8 1/2"	11"
7 1/2	9"	11 3/4"
8	9 5/8"	12 1/2"
8 1/2	10 1/4"	13 1/4"
9	10 7/8"	14 1/8"
9 1/2	11 1/2"	14 7/8"
10	12"	15 5/8"
10 1/2	12 5/8"	16 3/8"
11	13 1/4"	17 1/4"
11 1/2	13 3/8"	18"

Spacing In.	Jack Rafter Length
1	1 1/4"
2	2 3/8"
3	3 5/8"
4	4 3/4"
5	6"
6	7 1/4"
7	8 3/8"
8	9 5/8"
9	10 7/8"
10	1' 0"
11	1' 1 1/4"
12	1' 2 3/8"
13	1' 3 5/8"
14	1' 4 7/8"
15	1' 6"
16	1' 7 1/4"
17	1' 8 3/8"
18	1' 9 5/8"
19	1' 10 7/8"
20	2' 0"
21	2' 1 1/4"
22	2' 2 1/2"
23	2' 3 5/8"
24	2' 4 7/8"

Rafter Thickness	Miter Allowance for Hip and Valley Rafters	Rafter Depth	Bottom Allowance
1 1/2"	7/8"	3 1/2"	2 5/16"
1 5/8"	1"	5 1/2"	3 11/16"
1 3/4"	1 1/16"	7 1/4"	4 13/16"
1 7/8"	1 1/8"	9 1/4"	6 3/16"

9 INCH RISE

9-12 PITCH 37 DEGREES

Run Ft.	Common Rafter Length	Hip or Val. Rafter Length
1	1' 3"	1' 7 $\frac{1}{4}$ "
2	2' 6"	3' 2 $\frac{3}{8}$ "
3	3' 9"	4' 9 $\frac{5}{8}$ "
4	5' 0"	6' 4 $\frac{7}{8}$ "
5	6' 3"	8' 0 $\frac{7}{8}$ "
6	7' 6"	9' 7 $\frac{1}{4}$ "
7	8' 9"	11' 2 $\frac{1}{2}$ "
8	10' 0"	12' 9 $\frac{3}{4}$ "
9	11' 3"	14' 4 $\frac{7}{8}$ "
10	12' 6"	16' 0 $\frac{7}{8}$ "
11	13' 9"	17' 7 $\frac{3}{8}$ "
12	15' 0"	19' 2 $\frac{1}{2}$ "
13	16' 3"	20' 9 $\frac{3}{4}$ "
14	17' 6"	22' 5"
15	18' 9"	24' 0 $\frac{1}{8}$ "
16	20' 0"	25' 7 $\frac{3}{8}$ "
17	21' 3"	27' 2 $\frac{5}{8}$ "
18	22' 6"	28' 9 $\frac{3}{4}$ "
19	23' 9"	30' 5"
20	25' 0"	32' 0 $\frac{1}{4}$ "
21	26' 3"	33' 7 $\frac{3}{8}$ "
22	27' 6"	35' 2 $\frac{5}{8}$ "
23	28' 9"	36' 9 $\frac{7}{8}$ "
24	30' 0"	38' 5"
25	31' 3"	40' 0 $\frac{1}{4}$ "

Run In.	Common Rafter Length	Hip or Val. Rafter Length
$\frac{1}{2}$	$\frac{5}{8}$ "	$\frac{3}{4}$ "
1	1 $\frac{1}{4}$ "	1 $\frac{5}{8}$ "
1 $\frac{1}{2}$	1 $\frac{7}{8}$ "	2 $\frac{3}{8}$ "
2	2 $\frac{1}{2}$ "	3 $\frac{1}{4}$ "
2 $\frac{1}{2}$	3 $\frac{1}{8}$ "	4"
3	3 $\frac{3}{4}$ "	4 $\frac{3}{4}$ "
3 $\frac{1}{2}$	4 $\frac{3}{8}$ "	5 $\frac{5}{8}$ "
4	5"	6 $\frac{3}{8}$ "
4 $\frac{1}{2}$	5 $\frac{5}{8}$ "	7 $\frac{1}{4}$ "
5	6 $\frac{1}{4}$ "	8"
5 $\frac{1}{2}$	6 $\frac{5}{8}$ "	8 $\frac{3}{4}$ "
6	7 $\frac{1}{2}$ "	9 $\frac{5}{8}$ "
6 $\frac{1}{2}$	8 $\frac{1}{8}$ "	10 $\frac{3}{8}$ "
7	8 $\frac{3}{4}$ "	11 $\frac{1}{4}$ "
7 $\frac{1}{2}$	9 $\frac{3}{8}$ "	12"
8	10"	12 $\frac{7}{8}$ "
8 $\frac{1}{2}$	10 $\frac{3}{8}$ "	13 $\frac{5}{8}$ "
9	11 $\frac{1}{4}$ "	14 $\frac{3}{8}$ "
9 $\frac{1}{2}$	11 $\frac{5}{8}$ "	15 $\frac{1}{4}$ "
10	12 $\frac{1}{2}$ "	16"
10 $\frac{1}{2}$	13 $\frac{1}{8}$ "	16 $\frac{7}{8}$ "
11	13 $\frac{3}{4}$ "	17 $\frac{5}{8}$ "
11 $\frac{1}{2}$	14 $\frac{3}{8}$ "	18 $\frac{3}{8}$ "

Spacing In.	Jack Rafter Length
1	1 $\frac{1}{4}$ "
2	2 $\frac{1}{2}$ "
3	3 $\frac{3}{4}$ "
4	5"
5	6 $\frac{1}{4}$ "
6	7 $\frac{1}{2}$ "
7	8 $\frac{3}{4}$ "
8	10"
9	11 $\frac{1}{4}$ "
10	1' 0 $\frac{1}{2}$ "
11	1' 1 $\frac{3}{4}$ "
12	1' 3"
13	1' 4 $\frac{1}{4}$ "
14	1' 5 $\frac{1}{2}$ "
15	1' 6 $\frac{3}{4}$ "
16	1' 8"
17	1' 9 $\frac{1}{4}$ "
18	1' 10 $\frac{1}{2}$ "
19	1' 11 $\frac{3}{4}$ "
20	2' 1"
21	2' 2 $\frac{1}{4}$ "
22	2' 3 $\frac{1}{2}$ "
23	2' 4 $\frac{3}{4}$ "
24	2' 6"

Rafter Thickness	Miter Allowance for Hip and Valley Rafters	Rafter Depth	Bottom Allowance
1 $\frac{1}{2}$ "	1 $\frac{5}{16}$ "	3 $\frac{1}{2}$ "	2 $\frac{3}{8}$ "
1 $\frac{3}{8}$ "	1"	5 $\frac{1}{2}$ "	4 $\frac{1}{8}$ "
1 $\frac{3}{4}$ "	1 $\frac{1}{8}$ "	7 $\frac{1}{4}$ "	5 $\frac{7}{16}$ "
1 $\frac{7}{8}$ "	1 $\frac{3}{16}$ "	9 $\frac{1}{4}$ "	6 $\frac{15}{16}$ "

10 INCH RISE

10-12 PITCH 40 DEGREES

Run Ft.	Common Rafter Length	Hip or Val. Rafter Length
1	1' 3 $\frac{3}{8}$ "	1' 7 $\frac{3}{4}$ "
2	2' 7 $\frac{1}{4}$ "	3' 3 $\frac{3}{8}$ "
3	3' 10 $\frac{3}{8}$ "	4' 1 $\frac{1}{8}$ "
4	4' 5' 2 $\frac{1}{2}$ "	6' 6 $\frac{3}{4}$ "
5	5' 6' 6 $\frac{3}{8}$ "	8' 2' 2 $\frac{1}{2}$ "
6	6' 7' 9 $\frac{3}{4}$ "	9' 10 $\frac{1}{4}$ "
7	7' 9' 1 $\frac{3}{8}$ "	11' 5 $\frac{1}{8}$ "
8	8' 10' 5"	13' 1 $\frac{5}{8}$ "
9	9' 11' 8 $\frac{3}{8}$ "	14' 9 $\frac{1}{4}$ "
10	10' 13' 0 $\frac{1}{4}$ "	16' 5"
11	11' 14' 3 $\frac{1}{2}$ "	18' 0 $\frac{3}{4}$ "
12	12' 15' 7 $\frac{1}{2}$ "	19' 8 $\frac{3}{8}$ "
13	13' 16' 11 $\frac{1}{8}$ "	21' 4 $\frac{1}{8}$ "
14	14' 18' 2 $\frac{3}{4}$ "	22' 1 $\frac{3}{4}$ "
15	15' 19' 6 $\frac{3}{8}$ "	24' 7 $\frac{1}{2}$ "
16	16' 20' 10"	26' 3 $\frac{1}{8}$ "
17	17' 22' 1 $\frac{5}{8}$ "	27' 10 $\frac{3}{8}$ "
18	18' 23' 5 $\frac{1}{4}$ "	29' 6 $\frac{3}{8}$ "
19	19' 24' 8 $\frac{3}{4}$ "	31' 2 $\frac{1}{4}$ "
20	20' 26' 0 $\frac{3}{8}$ "	32' 10"
21	21' 27' 4"	34' 5 $\frac{3}{8}$ "
22	22' 28' 7 $\frac{3}{8}$ "	36' 1 $\frac{3}{8}$ "
23	23' 29' 11 $\frac{1}{4}$ "	37' 9 $\frac{1}{8}$ "
24	24' 31' 2 $\frac{1}{8}$ "	39' 4 $\frac{1}{4}$ "
25	25' 32' 6 $\frac{1}{2}$ "	41' 0 $\frac{1}{2}$ "

Run In.	Common Rafter Length	Hip or Val. Rafter Length
$\frac{1}{2}$	$\frac{5}{8}$ "	$\frac{3}{8}$ "
1	1 $\frac{1}{4}$ "	1 $\frac{1}{8}$ "
1 $\frac{1}{2}$	2"	2 $\frac{1}{2}$ "
2	2 $\frac{5}{8}$ "	3 $\frac{1}{4}$ "
2 $\frac{1}{2}$	3 $\frac{1}{4}$ "	4 $\frac{1}{8}$ "
3	3 $\frac{3}{8}$ "	4 $\frac{3}{8}$ "
3 $\frac{1}{2}$	4 $\frac{1}{2}$ "	5 $\frac{1}{4}$ "
4	5 $\frac{1}{4}$ "	6 $\frac{3}{8}$ "
4 $\frac{1}{2}$	5 $\frac{5}{8}$ "	7 $\frac{3}{8}$ "
5	6 $\frac{1}{2}$ "	8 $\frac{1}{4}$ "
5 $\frac{1}{2}$	7 $\frac{1}{8}$ "	9"
6	7 $\frac{3}{4}$ "	9 $\frac{5}{8}$ "
6 $\frac{1}{2}$	8 $\frac{1}{2}$ "	10 $\frac{3}{4}$ "
7	9 $\frac{1}{8}$ "	11 $\frac{1}{2}$ "
7 $\frac{1}{2}$	9 $\frac{3}{4}$ "	12 $\frac{3}{8}$ "
8	10 $\frac{3}{8}$ "	13 $\frac{1}{8}$ "
8 $\frac{1}{2}$	11 $\frac{1}{8}$ "	14"
9	11 $\frac{3}{4}$ "	14 $\frac{3}{4}$ "
9 $\frac{1}{2}$	12 $\frac{3}{8}$ "	15 $\frac{5}{8}$ "
10	13"	16 $\frac{1}{2}$ "
10 $\frac{1}{2}$	13 $\frac{5}{8}$ "	17 $\frac{1}{4}$ "
11	14 $\frac{3}{8}$ "	18 $\frac{1}{8}$ "
11 $\frac{1}{2}$	15"	18 $\frac{3}{8}$ "

Spacing In.	Jack Rafter Length
1	1 $\frac{1}{4}$ "
2	2 $\frac{3}{8}$ "
3	3 $\frac{3}{8}$ "
4	5 $\frac{1}{4}$ "
5	6 $\frac{1}{2}$ "
6	7 $\frac{3}{4}$ "
7	9 $\frac{1}{8}$ "
8	10 $\frac{3}{8}$ "
9	11 $\frac{3}{4}$ "
10	1' 1"
11	1' 2 $\frac{3}{8}$ "
12	1' 3 $\frac{3}{8}$ "
13	1' 4 $\frac{7}{8}$ "
14	1' 6 $\frac{1}{4}$ "
15	1' 7 $\frac{1}{2}$ "
16	1' 8 $\frac{3}{8}$ "
17	1' 10 $\frac{1}{8}$ "
18	1' 11 $\frac{3}{8}$ "
19	2' 0 $\frac{3}{4}$ "
20	2' 2"
21	2' 3 $\frac{3}{8}$ "
22	2' 4 $\frac{5}{8}$ "
23	2' 6"
24	2' 7 $\frac{1}{4}$ "

Rafter Thickness	Miter Allowance for Hip and Valley Rafters	Rafter Depth	Bottom Allowance
1 $\frac{1}{2}$ "	1"	3 $\frac{1}{2}$ "	2 $\frac{15}{16}$ "
1 $\frac{5}{8}$ "	1 $\frac{1}{16}$ "	5 $\frac{1}{2}$ "	4 $\frac{9}{16}$ "
1 $\frac{3}{4}$ "	1 $\frac{1}{8}$ "	7 $\frac{1}{4}$ "	6 $\frac{1}{16}$ "
1 $\frac{7}{8}$ "	1 $\frac{1}{4}$ "	9 $\frac{1}{4}$ "	7 $\frac{1}{16}$ "

11 INCH RISE

11-12 PITCH 42½ DEGREES

Run Ft.	Common Rafter Length	Hip or Val. Rafter Length
1	1' 4¼"	1' 8¼"
2	2' 8⅝"	3' 4½"
3	4' 0⅞"	5' 0⅞"
4	5' 5⅞"	6' 8⅞"
5	6' 9⅞"	8' 5⅞"
6	8' 1¾"	10' 1⅞"
7	9' 6"	11' 9⅞"
8	10' 10¼"	13' 5¼"
9	12' 2½"	15' 2"
10	13' 6¾"	16' 10¼"
11	14' 11⅞"	18' 6½"
12	16' 3⅜"	20' 2¾"
13	17' 7⅞"	21' 10⅞"
14	18' 11⅞"	23' 7⅞"
15	20' 4⅞"	25' 3⅞"
16	21' 8½"	26' 1⅞"
17	23' 0¾"	28' 7⅞"
18	24' 5"	30' 4"
19	25' 9⅜"	32' 0¼"
20	27' 1⅝"	33' 8½"
21	28' 5⅞"	35' 4¾"
22	29' 10⅞"	37' 1"
23	31' 2⅞"	38' 9⅞"
24	32' 6¾"	40' 5⅞"
25	33' 11"	42' 1⅞"

Run In.	Common Rafter Length	Hip or Val. Rafter Length
½	⅝"	⅞"
1	1⅜"	1⅝"
1½	2"	2½"
2	2¾"	3⅜"
2½	3⅝"	4¼"
3	4⅞"	5"
3½	4¾"	5⅞"
4	5⅝"	6¾"
4½	6⅞"	7⅝"
5	6¾"	8⅜"
5½	7½"	9¼"
6	8⅞"	10⅞"
6½	8⅞"	11"
7	9½"	11¾"
7½	10⅞"	12⅝"
8	10⅞"	13½"
8½	11½"	14⅜"
9	12¼"	15⅞"
9½	12⅞"	16"
10	13⅝"	16⅞"
10½	14¼"	17¾"
11	14⅞"	18½"
11½	15⅝"	19⅞"

Spacing In.	Jack Rafter Length
1	1⅜"
2	2⅝"
3	4⅞"
4	5⅝"
5	6¾"
6	8⅞"
7	9½"
8	10⅞"
9	1' 0¼"
10	1' 1⅝"
11	1' 2⅞"
12	1' 4¼"
13	1' 5⅞"
14	1' 7"
15	1' 8⅜"
16	1' 9¾"
17	1' 11"
18	2' 0⅞"
19	2' 1¾"
20	2' 3⅞"
21	2' 4⅞"
22	2' 5⅞"
23	2' 7¼"
24	2' 8½"

Rafter Thickness	Miter Allowance for Hip and Valley Rafters	Rafter Depth	Bottom Allowance
1½"	1"	3½"	3⅜"
1⅝"	1⅞"	5½"	5⅞"
1¾"	1¾"	7¼"	6⅞"
1⅞"	1¼"	9¼"	8½"

12 INCH RISE

12-12 PITCH 45 DEGREES

Run Ft.	Common Rafter Length	Hip or Val. Rafter Length
1	1' 5"	1' 8 $\frac{3}{4}$ "
2	2' 10"	3' 5 $\frac{1}{4}$ "
3	4' 2 $\frac{7}{8}$ "	5' 2 $\frac{3}{8}$ "
4	5' 7 $\frac{1}{8}$ "	6' 11 $\frac{1}{8}$ "
5	7' 0 $\frac{1}{8}$ "	8' 8"
6	8' 5 $\frac{1}{8}$ "	10' 4 $\frac{3}{4}$ "
7	9' 10 $\frac{1}{8}$ "	12' 1 $\frac{1}{2}$ "
8	11' 3 $\frac{1}{4}$ "	13' 10 $\frac{1}{4}$ "
9	12' 8 $\frac{1}{4}$ "	15' 7 $\frac{1}{8}$ "
10	14' 1 $\frac{3}{4}$ "	17' 3 $\frac{7}{8}$ "
11	15' 6 $\frac{3}{4}$ "	19' 0 $\frac{5}{8}$ "
12	16' 11 $\frac{3}{8}$ "	20' 9 $\frac{3}{8}$ "
13	18' 4 $\frac{1}{2}$ "	22' 6 $\frac{1}{4}$ "
14	19' 9 $\frac{1}{2}$ "	24' 3"
15	21' 2 $\frac{5}{8}$ "	25' 11 $\frac{3}{4}$ "
16	22' 7 $\frac{1}{2}$ "	27' 8 $\frac{3}{8}$ "
17	24' 0 $\frac{1}{2}$ "	29' 5 $\frac{3}{8}$ "
18	25' 5 $\frac{1}{2}$ "	31' 2 $\frac{1}{8}$ "
19	26' 10 $\frac{1}{2}$ "	32' 10 $\frac{1}{8}$ "
20	28' 3 $\frac{3}{8}$ "	34' 7 $\frac{3}{4}$ "
21	29' 8 $\frac{3}{8}$ "	36' 4 $\frac{1}{2}$ "
22	31' 1 $\frac{3}{8}$ "	38' 1 $\frac{1}{4}$ "
23	32' 6 $\frac{3}{8}$ "	39' 10"
24	33' 11 $\frac{1}{4}$ "	41' 6 $\frac{3}{8}$ "
25	35' 4 $\frac{1}{4}$ "	43' 3 $\frac{3}{8}$ "

Run In.	Common Rafter Length	Hip or Val. Rafter Length
$\frac{1}{2}$	$\frac{3}{4}$	$\frac{7}{8}$
1	1 $\frac{3}{8}$ "	1 $\frac{1}{4}$ "
1 $\frac{1}{2}$	2 $\frac{1}{8}$ "	2 $\frac{5}{8}$ "
2	2 $\frac{7}{8}$ "	3 $\frac{1}{2}$ "
2 $\frac{1}{2}$	3 $\frac{1}{2}$ "	4 $\frac{3}{8}$ "
3	4 $\frac{1}{4}$ "	5 $\frac{1}{4}$ "
3 $\frac{1}{2}$	5"	6"
4	5 $\frac{5}{8}$ "	6 $\frac{3}{8}$ "
4 $\frac{1}{2}$	6 $\frac{3}{8}$ "	7 $\frac{3}{4}$ "
5	7 $\frac{1}{8}$ "	8 $\frac{3}{8}$ "
5 $\frac{1}{2}$	7 $\frac{3}{4}$ "	9 $\frac{1}{2}$ "
6	8 $\frac{1}{2}$ "	10 $\frac{3}{8}$ "
6 $\frac{1}{2}$	9"	11 $\frac{1}{4}$ "
7	9 $\frac{5}{8}$ "	12 $\frac{1}{8}$ "
7 $\frac{1}{2}$	10 $\frac{5}{8}$ "	13"
8	11 $\frac{1}{8}$ "	13 $\frac{3}{8}$ "
8 $\frac{1}{2}$	12"	14 $\frac{3}{4}$ "
9	12 $\frac{3}{4}$ "	15 $\frac{5}{8}$ "
9 $\frac{1}{2}$	13 $\frac{1}{2}$ "	16 $\frac{1}{2}$ "
10	14 $\frac{1}{8}$ "	17 $\frac{3}{8}$ "
10 $\frac{1}{2}$	14 $\frac{1}{8}$ "	18 $\frac{1}{8}$ "
11	15 $\frac{5}{8}$ "	19"
11 $\frac{1}{2}$	16 $\frac{1}{4}$ "	19 $\frac{1}{8}$ "

Spacing In.	Jack Rafter Length
1	1 $\frac{3}{8}$ "
2	2 $\frac{7}{8}$ "
3	4 $\frac{1}{4}$ "
4	5 $\frac{5}{8}$ "
5	7 $\frac{1}{8}$ "
6	8 $\frac{7}{2}$ "
7	9 $\frac{7}{8}$ "
8	11 $\frac{3}{8}$ "
9	1' 0 $\frac{3}{4}$ "
10	1' 2 $\frac{1}{8}$ "
11	1' 3 $\frac{1}{2}$ "
12	1' 5"
13	1' 6 $\frac{3}{8}$ "
14	1' 7 $\frac{3}{4}$ "
15	1' 9 $\frac{1}{4}$ "
16	1' 10 $\frac{3}{8}$ "
17	2' 0"
18	2' 1 $\frac{1}{2}$ "
19	2' 2 $\frac{7}{8}$ "
20	2' 4 $\frac{1}{4}$ "
21	2' 5 $\frac{3}{4}$ "
22	2' 7 $\frac{1}{8}$ "
23	2' 8 $\frac{1}{2}$ "
24	2' 10"

Rafter Thickness	Miter Allowance for Hip and Valley Rafters	Rafter Depth	Bottom Allowance
1 $\frac{1}{2}$ "	1 $\frac{1}{16}$ "	3 $\frac{1}{2}$ "	3 $\frac{1}{2}$ "
1 $\frac{5}{8}$ "	1 $\frac{1}{8}$ "	5 $\frac{1}{2}$ "	5 $\frac{1}{2}$ "
1 $\frac{3}{4}$ "	1 $\frac{1}{4}$ "	7 $\frac{1}{4}$ "	7 $\frac{1}{4}$ "
1 $\frac{7}{8}$ "	1 $\frac{5}{16}$ "	9 $\frac{1}{4}$ "	9 $\frac{1}{4}$ "

13 INCH RISE

13-12 PITCH 47 1/4 DEGREES

Run Ft.	Common Rafter Length	Hip or Val. Rafter Length
1	1' 5 3/4"	1' 9 3/8"
2	2' 11 3/8"	3' 6 3/4"
3	4' 5 5/8"	5' 4 7/8"
4	5' 10 3/4"	7' 1 1/2"
5	7' 4 1/2"	8' 10 7/8"
6	8' 10 1/8"	10' 8 1/4"
7	10' 3 3/8"	12' 5 7/8"
8	11' 9 1/2"	14' 3"
9	13' 3 1/4"	16' 0 3/8"
10	14' 9"	17' 9 3/4"
11	16' 2 5/8"	19' 7 7/8"
12	17' 8 3/8"	21' 4 1/2"
13	19' 2"	23' 1 7/8"
14	20' 7 3/4"	24' 11 1/4"
15	22' 1 3/8"	26' 8 5/8"
16	23' 7 1/8"	28' 6"
17	25' 0 3/4"	30' 3 3/8"
18	26' 6 1/2"	32' 0 7/8"
19	28' 0 1/8"	33' 10 1/4"
20	29' 5 5/8"	35' 7 5/8"
21	30' 11 1/2"	37' 5"
22	32' 5 1/4"	39' 2 3/8"
23	33' 10 7/8"	40' 11 3/4"
24	35' 4 5/8"	42' 9 1/8"
25	36' 10 3/8"	44' 6 1/2"

Run In.	Common Rafter Length	Hip or Val. Rafter Length
1/2	3/4"	7/8"
1	1 1/2"	1 3/4"
1 1/2	2 1/4"	2 5/8"
2	3"	3 5/8"
2 1/2	3 3/8"	4 1/2"
3	4 3/8"	5 5/8"
3 1/2	5 1/8"	6 1/2"
4	5 5/8"	7 1/8"
4 1/2	6 3/8"	8"
5	7 3/8"	8 7/8"
5 1/2	8 1/8"	9 3/4"
6	8 7/8"	10 3/4"
6 1/2	9 5/8"	11 5/8"
7	10 3/8"	12 1/2"
7 1/2	11"	13 3/8"
8	11 3/4"	14 1/4"
8 1/2	12 1/2"	15 1/8"
9	13 1/4"	16"
9 1/2	14"	16 7/8"
10	14 3/4"	17 7/8"
10 1/2	15 1/2"	18 3/4"
11	16 1/4"	19 5/8"
11 1/2	17"	20 1/2"

Spacing In.	Jack Rafter Length
1	1 1/2"
2	3"
3	4 3/8"
4	5 5/8"
5	7 3/8"
6	8 7/8"
7	10 3/8"
8	11 3/4"
9	1' 1 1/4"
10	1' 2 3/4"
11	1' 4 1/4"
12	1' 5 3/4"
13	1' 7 1/8"
14	1' 8 5/8"
15	1' 10 1/8"
16	1' 11 5/8"
17	2' 1 1/8"
18	2' 2 1/2"
19	2' 4"
20	2' 5 1/2"
21	2' 7"
22	2' 8 3/8"
23	2' 9 5/8"
24	2' 11 3/8"

Rafter Thickness	Miter Allowance for Hip and Valley Rafters	Rafter Depth	Bottom Allowance
1 1/2"	1 1/8"	3 1/2"	3 13/16"
1 5/8"	1 3/16"	5 1/2"	5 15/16"
1 3/4"	1 5/16"	7 1/4"	7 7/8"
1 7/8"	1 3/8"	9 1/4"	10"

14 INCH RISE

14-12 PITCH 49½ DEGREES

Run Ft.	Common Rafter Length	Hip or Val. Rafter Length
1	1' 6½"	1' 10"
2	3' 0½"	3' 8"
3	4' 7¾"	5' 6"
4	6' 1¾"	7' 4"
5	7' 8¼"	9' 2"
6	9' 2¾"	11' 0"
7	10' 9½"	12' 10"
8	12' 3½"	14' 8"
9	13' 10"	16' 6"
10	15' 4¾"	18' 4"
11	16' 10½"	20' 2"
12	18' 5¼"	22' 0"
13	19' 11¾"	23' 10"
14	21' 6½"	25' 8"
15	23' 0¾"	27' 6"
16	24' 7"	29' 4"
17	26' 1½"	31' 2"
18	27' 7½"	33' 0"
19	29' 2¾"	34' 10"
20	30' 8¾"	36' 8"
21	32' 3¼"	38' 6"
22	33' 9¾"	40' 4"
23	35' 4½"	42' 2"
24	36' 10½"	44' 0"
25	38' 5"	45' 10"

Run In.	Common Rafter Length	Hip or Val. Rafter Length
½	¾"	7⁄8"
1	1½"	1⅞"
1½	2¼"	2¾"
2	3⅜"	3½"
2½	3⅞"	4⅞"
3	4⅝"	5½"
3½	5¾"	6¾"
4	6⅞"	7¾"
4½	6⅞"	8¼"
5	7⅞"	9⅞"
5½	8½"	10⅞"
6	9¼"	11"
6½	10"	11⅞"
7	10¾"	12⅞"
7½	11½"	13¾"
8	12¾"	14⅞"
8½	13⅞"	15⅞"
9	13⅞"	16½"
9½	14⅞"	17¾"
10	15¾"	18¾"
10½	16⅞"	19¼"
11	16⅞"	20⅞"
11½	17¾"	21⅞"

Spacing In.	Jack Rafter Length
1	1½"
2	3⅞"
3	4⅝"
4	6⅞"
5	7¾"
6	9¼"
7	10¾"
8	1' 0¼"
9	1' 1⅞"
10	1' 3¾"
11	1' 4⅞"
12	1' 6½"
13	1' 8"
14	1' 9½"
15	1' 11"
16	2' 0¾"
17	2' 2⅞"
18	2' 3¾"
19	2' 5¼"
20	2' 6¾"
21	2' 8¼"
22	2' 9⅞"
23	2' 11¾"
24	3' 0⅞"

Rafter Thickness	Miter Allowance for Hip and Valley Rafters	Rafter Depth	Bottom Allowance
1½"	1⅛"	3½"	4⅛"
1⅝"	1¼"	5½"	6⅛"
1¾"	1¾"	7¼"	8⅛"
1⅞"	1⅞"	9¼"	10⅛"

15 INCH RISE

15-12 PITCH 51½ DEGREES

Run Ft.	Common Rafter Length	Hip or Val. Rafter Length
1	1' 7¼"	1' 10½"
2	3' 2¾"	3' 9¾"
3	4' 9¾"	5' 8"
4	6' 4¾"	7' 6¾"
5	8' 0⅞"	9' 5¼"
6	9' 7¼"	11' 3⅝"
7	11' 2½"	13' 2⅝"
8	12' 9¾"	15' 1¼"
9	14' 4⅞"	16' 11⅞"
10	16' 0⅞"	18' 10½"
11	17' 7¾"	20' 9⅞"
12	19' 2½"	22' 7⅞"
13	20' 9¾"	24' 6½"
14	22' 5"	26' 5⅞"
15	24' 0⅞"	28' 3¼"
16	25' 7¾"	30' 2⅝"
17	27' 2⅝"	32' 1"
18	28' 9¾"	33' 11¼"
19	30' 5"	35' 10¾"
20	32' 0¼"	37' 9"
21	33' 7¾"	39' 7⅝"
22	35' 2⅝"	41' 6¼"
23	36' 9⅞"	43' 5"
24	38' 5"	45' 3⅝"
25	40' 0¼"	47' 2¼"

Run In.	Common Rafter Length	Hip or Val. Rafter Length
½	¾"	1"
1	1⅝"	1⅞"
1½	2¾"	2⅞"
2	3¼"	3¾"
2½	4"	4¾"
3	4¾"	5⅞"
3½	5⅝"	6⅞"
4	6¾"	7½"
4½	7¼"	8½"
5	8"	9½"
5½	8¾"	10⅞"
6	9⅝"	11⅞"
6½	10⅞"	12¾"
7	11¼"	13¼"
7½	12"	14¼"
8	12⅞"	15⅞"
8½	13⅝"	16⅞"
9	14¾"	17"
9½	15¼"	18"
10	16"	18⅞"
10½	16⅞"	19⅞"
11	17⅝"	20⅞"
11½	18¾"	21¾"

Spacing In.	Jack Rafter Length
1	1⅝"
2	3¼"
3	4¾"
4	6⅞"
5	8"
6	9⅞"
7	11¼"
8	1' 0¾"
9	1' 2¾"
10	1' 4"
11	1' 5⅞"
12	1' 7¼"
13	1' 8¾"
14	1' 10⅞"
15	2' 0"
16	2' 1⅞"
17	2' 3¼"
18	2' 4⅞"
19	2' 6¾"
20	2' 8"
21	2' 9⅞"
22	2' 11¼"
23	3' 0⅞"
24	3' 2¾"

Rafter Thickness	Miter Allowance for Hip and Valley Rafters	Rafter Depth	Bottom Allowance
1½"	1¾"	3½"	4¾"
1⅝"	1⅝"	5½"	6⅞"
1¾"	1⅜"	7¼"	9¼"
1⅞"	1½"	9¼"	11⅞"

16 INCH RISE

16-12 PITCH 53 1/4 DEGREES

Run Ft.	Common Rafter Length	Hip or Val. Rafter Length
1	1' 8"	1' 11 3/8"
2	3' 4"	3' 10 5/8"
3	5' 0"	5' 10"
4	6' 8"	7' 9 3/8"
5	8' 4"	9' 8 3/8"
6	10' 0"	11' 8"
7	11' 8"	13' 7 1/4"
8	13' 4"	15' 6 3/8"
9	15' 0"	17' 5 1/8"
10	16' 8"	19' 5 1/4"
11	18' 4"	21' 4 5/8"
12	20' 0"	23' 3 3/8"
13	21' 8"	25' 3 1/8"
14	23' 4"	27' 2 1/2"
15	25' 0"	29' 1 1/8"
16	26' 8"	31' 1 1/4"
17	28' 4"	33' 0 1/2"
18	30' 0"	34' 1 1/8"
19	31' 8"	36' 1 1/8"
20	33' 4"	38' 10 1/2"
21	35' 0"	40' 9 7/8"
22	36' 8"	42' 9 3/8"
23	38' 4"	44' 8 1/2"
24	40' 0"	46' 7 3/4"
25	41' 8"	48' 7 1/8"

Run In.	Common Rafter Length	Hip or Val. Rafter Length
1/2	7/8"	1"
1	1 5/8"	2"
1 1/2	2 1/2"	2 7/8"
2	3 3/8"	3 3/8"
2 1/2	4 1/8"	4 7/8"
3	5"	5 5/8"
3 1/2	5 7/8"	6 3/4"
4	6 3/8"	7 3/4"
4 1/2	7 1/2"	8 3/4"
5	8 3/8"	9 3/4"
5 1/2	9 1/8"	10 3/4"
6	10"	11 5/8"
6 1/2	10 7/8"	12 5/8"
7	11 5/8"	13 5/8"
7 1/2	12 1/2"	14 5/8"
8	13 3/8"	15 1/2"
8 1/2	14 1/8"	16 1/2"
9	15"	17 1/2"
9 1/2	15 5/8"	18 1/2"
10	16 5/8"	19 5/8"
10 1/2	17 1/2"	20 3/8"
11	18 3/8"	21 3/8"
11 1/2	19 3/8"	22 3/8"

Spacing In.	Jack Rafter Length
1	1 5/8"
2	3 3/8"
3	5"
4	6 5/8"
5	8 3/8"
6	10"
7	11 5/8"
8	1' 1 3/8"
9	1' 3"
10	1' 4 5/8"
11	1' 6 3/8"
12	1' 8"
13	1' 9 5/8"
14	1' 11 3/8"
15	2' 1"
16	2' 2 5/8"
17	2' 4 3/8"
18	2' 6"
19	2' 7 5/8"
20	2' 9 3/8"
21	2' 11"
22	3' 0 5/8"
23	3' 2 3/8"
24	3' 4"

Rafter Thickness	Miter Allowance for Hip and Valley Rafters	Rafter Depth	Bottom Allowance
1 1/2"	1 1/4"	3 1/2"	4 1 1/16"
1 5/8"	1 3/8"	5 1/2"	7 5/16"
1 3/4"	1 7/16"	7 1/4"	9 1 1/16"
1 7/8"	1 9/16"	9 1/4"	12 5/16"

17 INCH RISE

17-12 PITCH 54¾ DEGREES

Run Ft.	Common Rafter Length	Hip or Val. Rafter Length
1	1' 8 ⁷ / ₈ "	2' 0"
2	3' 5 ³ / ₈ "	4' 0"
3	5' 2 ¹ / ₂ "	6' 0 ¹ / ₈ "
4	6' 11 ¹ / ₄ "	8' 0 ¹ / ₈ "
5	8' 8"	10' 0 ¹ / ₈ "
6	10' 4 ⁷ / ₈ "	12' 0 ¹ / ₈ "
7	12' 1 ¹ / ₈ "	14' 0 ¹ / ₈ "
8	13' 10 ¹ / ₂ "	16' 0 ¹ / ₈ "
9	15' 7 ¹ / ₄ "	18' 0 ¹ / ₄ "
10	17' 4 ¹ / ₈ "	20' 0 ¹ / ₄ "
11	19' 0 ¹ / ₈ "	22' 0 ¹ / ₄ "
12	20' 9 ³ / ₄ "	24' 0 ¹ / ₄ "
13	22' 6 ¹ / ₂ "	26' 0 ¹ / ₄ "
14	24' 3 ³ / ₈ "	28' 0 ¹ / ₄ "
15	26' 0 ¹ / ₈ "	30' 0 ³ / ₈ "
16	27' 9"	32' 0 ³ / ₈ "
17	29' 5 ³ / ₄ "	34' 0 ³ / ₈ "
18	31' 2 ⁵ / ₈ "	36' 0 ³ / ₈ "
19	32' 11 ³ / ₈ "	38' 0 ³ / ₈ "
20	34' 8 ¹ / ₄ "	40' 0 ¹ / ₂ "
21	36' 5"	42' 0 ¹ / ₂ "
22	38' 1 ³ / ₄ "	44' 0 ¹ / ₂ "
23	39' 10 ⁵ / ₈ "	46' 0 ¹ / ₂ "
24	41' 7 ³ / ₈ "	48' 0 ¹ / ₂ "
25	43' 4 ¹ / ₄ "	50' 0 ¹ / ₂ "

Run In.	Common Rafter Length	Hip or Val. Rafter Length
½	¾"	1"
1	1¾"	2"
1½	2½"	3"
2	3½"	4"
2½	4¾"	5"
3	5¼"	6"
3½	6½"	7"
4	7"	8"
4½	7¾"	9"
5	8¾"	10"
5½	9½"	11"
6	10¾"	12"
6½	11¼"	13"
7	12½"	14"
7½	13"	15"
8	13¾"	16"
8½	14¾"	17"
9	15¾"	18"
9½	16½"	19"
10	17¾"	20"
10½	18¼"	21"
11	19½"	22"
11½	20"	23"

Spacing In.	Jack Rafter Length
1	1¾"
2	3½"
3	5¼"
4	6¾"
5	8¾"
6	10¾"
7	1' 0 ¹ / ₈ "
8	1' 1 ¹ / ₈ "
9	1' 3 ³ / ₈ "
10	1' 5 ⁵ / ₈ "
11	1' 7 ⁷ / ₈ "
12	1' 8¾"
13	1' 10½"
14	2' 0¼"
15	2' 2"
16	2' 3¾"
17	2' 5½"
18	2' 7¼"
19	2' 9"
20	2' 10¾"
21	3' 0¾"
22	3' 2½"
23	3' 3¾"
24	3' 5¾"

Rafter Thickness	Miter Allowance for Hip and Valley Rafters	Rafter Depth	Bottom Allowance
1½"	1 ⁵ / ₁₆ "	3½"	4 ¹⁵ / ₁₆ "
1 ⁵ / ₈ "	1 ⁷ / ₁₆ "	5½"	7 ¹³ / ₁₆ "
1¾"	1½"	7¼"	10¼"
1 ⁷ / ₈ "	1 ⁵ / ₈ "	9¼"	13 ¹ / ₈ "

18 INCH RISE

18-12 PITCH 56¼ DEGREES

Run Ft.	Common Rafter Length	Hip or Val. Rafter Length
1	1' 9 5/8"	2' 0 3/4"
2	3' 7 1/4"	4' 1 1/2"
3	5' 4 1/8"	6' 2 1/4"
4	7' 2 1/2"	8' 3"
5	9' 0 1/8"	10' 3 3/4"
6	10' 9 7/8"	12' 4 3/8"
7	12' 7 1/2"	14' 5 1/4"
8	14' 5 1/8"	16' 5 5/8"
9	16' 2 3/4"	18' 6 5/8"
10	18' 0 3/8"	20' 7 5/8"
11	19' 10"	22' 8 1/8"
12	21' 7 5/8"	24' 8 7/8"
13	23' 5 1/4"	26' 9 5/8"
14	25' 2 1/8"	28' 10 3/8"
15	27' 0 1/2"	30' 11 1/8"
16	28' 10 1/8"	32' 11 7/8"
17	30' 7 3/4"	35' 0 5/8"
18	32' 5 3/8"	37' 1 3/8"
19	34' 3"	39' 2"
20	36' 0 5/8"	41' 2 3/4"
21	37' 10 3/8"	43' 3 1/2"
22	39' 7 7/8"	45' 4 1/4"
23	41' 5 5/8"	47' 5"
24	43' 3 1/4"	49' 5 3/4"
25	45' 0 7/8"	51' 6 1/2"

Run In.	Common Rafter Length	Hip or Val. Rafter Length
1/2	7/8"	1"
1	1 3/4"	2"
1 1/2	2 3/4"	3 3/8"
2	3 5/8"	4 1/8"
2 1/2	4 1/2"	5 1/8"
3	5 3/8"	6 1/8"
3 1/2	6 1/4"	7 1/4"
4	7 1/4"	8 1/4"
4 1/2	8 1/8"	9 1/4"
5	9"	10 1/4"
5 1/2	9 7/8"	11 3/8"
6	10 7/8"	12 3/8"
6 1/2	11 1/4"	13 3/8"
7	12 5/8"	14 3/8"
7 1/2	13 5/8"	15 1/2"
8	14 1/2"	16 1/2"
8 1/2	15 5/8"	17 1/2"
9	16 1/4"	18 1/2"
9 1/2	17 1/8"	19 5/8"
10	18 1/8"	20 5/8"
10 1/2	19"	21 5/8"
11	19 7/8"	22 5/8"
11 1/2	20 3/4"	23 3/4"

Spacing In.	Jack Rafter Length
1	1 3/4"
2	3 5/8"
3	5 3/8"
4	7 1/4"
5	9"
6	10 7/8"
7	1' 0 5/8"
8	1' 2 3/8"
9	1' 4 1/4"
10	1' 6"
11	1' 7 7/8"
12	1' 9 5/8"
13	1' 11 1/2"
14	2' 1 1/4"
15	2' 3"
16	2' 4 7/8"
17	2' 6 5/8"
18	2' 8 1/2"
19	2' 10 1/4"
20	3' 0"
21	3' 1 7/8"
22	3' 3 5/8"
23	3' 5 1/2"
24	3' 7 1/4"

Rafter Thickness	Miter Allowance for Hip and Valley Rafters	Rafter Depth	Bottom Allowance
1 1/2"	1 3/8"	3 1/2"	5 1/4"
1 5/8"	1 7/16"	5 1/2"	8 1/4"
1 3/4"	1 9/16"	7 1/4"	10 7/8"
1 7/8"	1 11/16"	9 1/4"	13 7/8"

19 INCH RISE

19-12 PITCH 57 1/4 DEGREES

Run Ft.	Common Rafter Length	Hip or Val. Rafter Length
1	1' 10 1/2"	2' 1 1/2"
2	3' 9"	4' 3"
3	5' 7 3/8"	6' 4 1/2"
4	7' 5 7/8"	8' 5 1/8"
5	9' 4 3/8"	10' 7 3/8"
6	11' 2 7/8"	12' 8 7/8"
7	13' 1 3/8"	14' 10 3/8"
8	14' 11 3/4"	16' 11 7/8"
9	16' 10 1/4"	19' 1 1/4"
10	18' 8 3/4"	21' 2 3/4"
11	20' 7 1/4"	23' 4 1/4"
12	22' 5 5/8"	25' 5 3/4"
13	24' 4 1/8"	27' 7 1/4"
14	26' 2 5/8"	29' 8 5/8"
15	28' 1 1/8"	31' 10 1/8"
16	29' 11 5/8"	33' 11 5/8"
17	31' 10"	36' 1 1/8"
18	33' 8 1/2"	38' 2 5/8"
19	35' 7"	40' 4"
20	37' 5 1/2"	42' 5 1/2"
21	39' 3 3/8"	44' 7"
22	41' 2 3/8"	46' 8 1/2"
23	43' 0 7/8"	48' 10"
24	44' 11 3/8"	50' 11 3/8"
25	46' 9 7/8"	53' 0 7/8"

Run In.	Common Rafter Length	Hip or Val. Rafter Length
1/2	7/8"	1"
1	1 1/8"	2 1/8"
1 1/2	2 3/4"	3 1/8"
2	3 3/4"	4 1/4"
2 1/2	4 5/8"	5 1/4"
3	5 5/8"	6 3/8"
3 1/2	6 1/2"	7 3/8"
4	7 1/2"	8 1/2"
4 1/2	8 3/8"	9 1/2"
5	9 3/8"	10 5/8"
5 1/2	10 1/4"	11 5/8"
6	11 1/4"	12 3/4"
6 1/2	12 1/8"	13 3/4"
7	13 3/8"	14 7/8"
7 1/2	14"	15 5/8"
8	15"	17"
8 1/2	15 5/8"	18"
9	16 5/8"	19 1/8"
9 1/2	17 3/4"	20 1/8"
10	18 3/4"	21 1/4"
10 1/2	19 5/8"	22 1/4"
11	20 5/8"	23 3/8"
11 1/2	21 1/2"	24 3/8"

Spacing In.	Jack Rafter Length
1	1 7/8"
2	3 3/4"
3	5 5/8"
4	7 1/2"
5	9 3/8"
6	11 1/4"
7	1' 1 1/8"
8	1' 3"
9	1' 4 7/8"
10	1' 6 3/4"
11	1' 8 5/8"
12	1' 10 1/2"
13	2' 0 3/8"
14	2' 2 1/4"
15	2' 4 7/8"
16	2' 6"
17	2' 7 7/8"
18	2' 9 3/4"
19	2' 11 5/8"
20	3' 1 1/2"
21	3' 3 3/8"
22	3' 5 1/4"
23	3' 7 7/8"
24	3' 9"

Rafter Thickness	Miter Allowance for Hip and Valley Rafters	Rafter Depth	Bottom Allowance
1 1/2"	1 3/8"	3 1/2"	5 9/16"
1 5/8"	1 1/2"	5 1/2"	8 11/16"
1 3/4"	1 5/8"	7 1/4"	11 1/2"
1 7/8"	1 3/4"	9 1/4"	14 5/8"

20 INCH RISE 20-12 PITCH 59 DEGREES

Run Ft.	Common Rafter Length	Hip or Val. Rafter Length
1	1' 11 ³ / ₈ "	2' 2 ¹ / ₄ "
2	3' 10 ⁵ / ₈ "	4' 4 ¹ / ₂ "
3	5' 10"	6' 6 ³ / ₄ "
4	7' 9 ³ / ₈ "	8' 8 ¹ / ₂ "
5	9' 8 ⁵ / ₈ "	10' 11 ¹ / ₈ "
6	11' 8"	13' 1 ³ / ₈ "
7	13' 7 ¹ / ₄ "	15' 3 ³ / ₈ "
8	15' 6 ⁵ / ₈ "	17' 5 ¹ / ₈ "
9	17' 5 ¹ / ₈ "	19' 8 ¹ / ₈ "
10	19' 5 ¹ / ₄ "	21' 10 ³ / ₈ "
11	21' 4 ⁵ / ₈ "	24' 0 ¹ / ₂ "
12	23' 3 ³ / ₈ "	26' 2 ³ / ₄ "
13	25' 3 ¹ / ₄ "	28' 5"
14	27' 2 ¹ / ₂ "	30' 7 ¹ / ₄ "
15	29' 1 ¹ / ₈ "	32' 9 ¹ / ₂ "
16	31' 1 ¹ / ₄ "	34' 11 ³ / ₄ "
17	33' 0 ¹ / ₂ "	37' 1 ¹ / ₈ "
18	34' 11 ¹ / ₈ "	39' 4 ¹ / ₈ "
19	36' 11 ¹ / ₈ "	41' 6 ³ / ₈ "
20	38' 10 ¹ / ₂ "	43' 8 ¹ / ₈ "
21	40' 9 ⁷ / ₈ "	45' 10 ¹ / ₈ "
22	42' 9 ¹ / ₈ "	48' 1 ¹ / ₈ "
23	44' 8 ¹ / ₂ "	50' 3 ¹ / ₄ "
24	46' 7 ³ / ₄ "	52' 5 ¹ / ₂ "
25	48' 7 ¹ / ₈ "	54' 7 ³ / ₄ "

Run In.	Common Rafter Length	Hip or Val. Rafter Length
½	1"	1 ¹ / ₈ "
1	2"	2 ¹ / ₈ "
1½	2 ¹ / ₈ "	3 ¹ / ₄ "
2	3 ¹ / ₈ "	4 ³ / ₈ "
2½	4 ¹ / ₈ "	5 ¹ / ₂ "
3	5 ¹ / ₈ "	6 ¹ / ₂ "
3½	6 ¹ / ₄ "	7 ⁵ / ₈ "
4	7 ³ / ₄ "	8 ³ / ₄ "
4½	8 ³ / ₄ "	9 ¹ / ₈ "
5	9 ¹ / ₄ "	10 ¹ / ₈ "
5½	10 ³ / ₄ "	12"
6	11 ⁵ / ₈ "	13 ³ / ₈ "
6½	12 ⁵ / ₈ "	14 ¹ / ₄ "
7	13 ³ / ₈ "	15 ¹ / ₄ "
7½	14 ⁵ / ₈ "	16 ³ / ₈ "
8	15 ¹ / ₂ "	17 ¹ / ₂ "
8½	16 ¹ / ₂ "	18 ⁵ / ₈ "
9	17 ¹ / ₂ "	19 ⁵ / ₈ "
9½	18 ¹ / ₂ "	20 ³ / ₄ "
10	19 ³ / ₈ "	21 ¹ / ₄ "
10½	20 ³ / ₈ "	23"
11	21 ³ / ₈ "	24"
11½	22 ³ / ₈ "	25 ¹ / ₈ "

Spacing In.	Jack Rafter Length
1	2"
2	3 ³ / ₈ "
3	5 ¹ / ₈ "
4	7 ³ / ₄ "
5	9 ³ / ₄ "
6	11 ¹ / ₈ "
7	1' 1 ¹ / ₈ "
8	1' 3 ¹ / ₂ "
9	1' 5 ¹ / ₂ "
10	1' 7 ³ / ₈ "
11	1' 9 ³ / ₈ "
12	1' 11 ³ / ₈ "
13	2' 1 ¹ / ₄ "
14	2' 3 ¹ / ₄ "
15	2' 5 ¹ / ₈ "
16	2' 7 ¹ / ₈ "
17	2' 9"
18	2' 11"
19	3' 0 ¹ / ₈ "
20	3' 2 ¹ / ₈ "
21	3' 4 ¹ / ₈ "
22	3' 6 ¹ / ₈ "
23	3' 8 ¹ / ₄ "
24	3' 10 ³ / ₈ "

Rafter Thickness	Miter Allowance for Hip and Valley Rafters	Rafter Depth	Bottom Allowance
1½"	1 ⁷ / ₁₆ "	3½"	5 ¹³ / ₁₆ "
1 ⁵ / ₈ "	1 ⁹ / ₁₆ "	5½"	9 ³ / ₁₆ "
1¾"	1 ¹¹ / ₁₆ "	7¼"	12 ¹ / ₁₆ "
1 ⁷ / ₈ "	1 ¹³ / ₁₆ "	9¼"	15 ¹ / ₁₆ "

21 INCH RISE

21-12 PITCH 60¼ DEGREES

Run Ft.	Common Rafter Length	Hip or Val. Rafter Length
1	2' 0¼"	2' 3"
2	4' 0¾"	4' 6"
3	6' 0⅝"	6' 9"
4	8' 0¾"	9' 0"
5	10' 1"	11' 3"
6	12' 1⅞"	13' 6"
7	14' 1¾"	15' 9"
8	16' 1½"	18' 0"
9	18' 1¾"	20' 3"
10	20' 1⅞"	22' 6"
11	22' 2⅞"	24' 9"
12	24' 2¼"	27' 0"
13	26' 2½"	29' 3"
14	28' 2⅝"	31' 6"
15	30' 2⅞"	33' 9"
16	32' 3"	36' 0"
17	34' 3¼"	38' 3"
18	36' 3⅝"	40' 6"
19	38' 3⅝"	42' 9"
20	40' 3¾"	45' 0"
21	42' 4"	47' 3"
22	44' 4⅞"	49' 6"
23	46' 4¾"	51' 9"
24	48' 4½"	54' 0"
25	50' 4⅝"	56' 3"

Run In.	Common Rafter Length	Hip or Val. Rafter Length
½	1"	1⅞"
1	2"	2¼"
1½	3"	3⅝"
2	4"	4⅞"
2½	5"	5⅝"
3	6"	6¾"
3½	7"	7⅞"
4	8⅞"	9"
4½	9⅞"	10⅞"
5	10⅞"	11¼"
5½	11⅞"	12¾"
6	12⅞"	13½"
6½	13⅞"	14⅝"
7	14⅞"	15¾"
7½	15⅞"	16⅞"
8	16⅞"	18"
8½	17⅞"	19⅞"
9	18⅞"	20¼"
9½	19⅞"	21¾"
10	20⅞"	22½"
10½	21¼"	23⅝"
11	22¼"	24¾"
11½	23¼"	25⅞"

Spacing In.	Jack Rafter Length
1	2"
2	4"
3	6"
4	8⅞"
5	10⅞"
6	1' 0⅞"
7	1' 2⅞"
8	1' 4⅞"
9	1' 6⅞"
10	1' 3⅞"
11	1' 10⅞"
12	2' 0¼"
13	2' 2¼"
14	2' 4¼"
15	2' 6¼"
16	2' 8¼"
17	2' 10¼"
18	3' 0¼"
19	3' 2¼"
20	3' 4⅞"
21	3' 6⅞"
22	3' 8⅞"
23	3' 10⅞"
24	4' 0⅞"

Rafter Thickness	Miter Allowance for Hip and Valley Rafters	Rafter Depth	Bottom Allowance
1½"	1½"	3½"	6⅞"
1⅝"	1⅝"	5½"	9⅝"
1¾"	1¾"	7¼"	12⅞"
1⅞"	1⅞"	9¼"	16⅞"

22 INCH RISE 22-12 PITCH 61½ DEGREES

Run Ft.	Common Rafter Length	Hip or Val. Rafter Length
1	2' 1 1/8"	2' 3 3/4"
2	4' 2 1/4"	4' 7 5/8"
3	6' 3 1/4"	6' 11 3/8"
4	8' 4 1/4"	9' 3 1/8"
5	10' 5 3/8"	11' 7"
6	12' 6 3/8"	13' 10 3/4"
7	14' 7 1/2"	16' 2 1/2"
8	16' 8 1/2"	18' 6 1/4"
9	18' 9 1/2"	20' 10 1/8"
10	20' 10 3/8"	23' 1 7/8"
11	22' 11 1/8"	25' 5 5/8"
12	25' 0 3/4"	27' 9 1/2"
13	27' 1 3/4"	30' 1 1/4"
14	29' 2 7/8"	32' 5"
15	31' 3 3/8"	34' 8 3/4"
16	33' 5"	37' 0 5/8"
17	35' 6"	39' 4 3/8"
18	37' 7 1/8"	41' 8 1/8"
19	39' 8 1/8"	43' 11 7/8"
20	41' 9 1/4"	46' 3 3/4"
21	43' 10 1/4"	48' 7 1/2"
22	45' 11 3/8"	50' 11 1/4"
23	48' 0 3/8"	53' 3 1/8"
24	50' 1 1/2"	55' 6 1/8"
25	52' 2 1/2"	57' 10 3/8"

Run In.	Common Rafter Length	Hip or Val. Rafter Length
1/2	1"	1 1/8"
1	2 1/8"	2 3/8"
1 1/2	3 3/8"	3 1/2"
2	4 4/8"	4 5/8"
2 1/2	5 1/2"	5 3/4"
3	6 1/4"	7"
3 1/2	7 1/4"	8 1/8"
4	8 3/8"	9 1/4"
4 1/2	9 3/8"	10 3/8"
5	10 1/2"	11 5/8"
5 1/2	11 1/2"	12 3/4"
6	12 1/2"	13 3/8"
6 1/2	13 5/8"	15"
7	14 5/8"	16 1/4"
7 1/2	15 5/8"	17 3/8"
8	16 3/4"	18 1/2"
8 1/2	17 3/4"	19 5/8"
9	18 3/4"	20 7/8"
9 1/2	19 7/8"	22"
10	20 7/8"	23 3/8"
10 1/2	21 7/8"	24 1/4"
11	23"	25 1/2"
11 1/2	24"	26 5/8"

Spacing In.	Jack Rafter Length
1	2 7/8"
2	4 1/8"
3	6 1/4"
4	8 3/8"
5	10 1/2"
6	1' 0 1/2"
7	1' 2 5/8"
8	1' 4 3/4"
9	1' 6 3/4"
10	1' 8 3/8"
11	1' 11"
12	2' 1"
13	2' 3 3/8"
14	2' 5 1/4"
15	2' 7 3/8"
16	2' 9 3/8"
17	2' 11 1/2"
18	3' 1 7/8"
19	3' 3 3/8"
20	3' 5 3/4"
21	3' 7 7/8"
22	3' 10"
23	4' 0"
24	4' 2 7/8"

Rafter Thickness	Miter Allowance for Hip and Valley Rafters	Rafter Depth	Bottom Allowance
1 1/2"	1 9/16"	3 1/2"	6 7/16"
1 5/8"	1 1 1/16"	5 1/2"	10 1/16"
1 3/4"	1 13/16"	7 1/4"	13 5/16"
1 7/8"	1 15/16"	9 1/4"	16 15/16"

23 INCH RISE

23-12 PITCH 62 1/2 DEGREES

Run Ft.	Common Rafter Length	Hip or Val. Rafter Length
1	2' 2"	2' 4 5/8"
2	4' 3 3/8"	4' 9 3/8"
3	6' 5 5/8"	7' 1 3/4"
4	8' 7 3/4"	9' 6 3/8"
5	10' 9 3/4"	11' 10 1/8"
6	12' 11 1/8"	14' 3 1/2"
7	15' 1 1/8"	16' 8 1/8"
8	17' 3 1/2"	19' 0 5/8"
9	19' 5 1/2"	21' 5 1/4"
10	21' 7 1/2"	23' 9 1/4"
11	23' 9 3/4"	26' 2 3/8"
12	25' 11 3/8"	28' 7"
13	28' 1 1/4"	30' 11 5/8"
14	30' 3 1/4"	33' 4 1/8"
15	32' 5 1/8"	35' 8 3/4"
16	34' 7 1/8"	38' 1 3/8"
17	36' 9"	40' 5 1/8"
18	38' 11"	42' 10 1/2"
19	41' 0 7/8"	45' 3 1/8"
20	43' 2 1/8"	47' 7 5/8"
21	45' 4 3/4"	50' 0 1/4"
22	47' 6 3/4"	52' 4 1/8"
23	49' 8 3/8"	54' 9 3/8"
24	51' 10 3/8"	57' 2"
25	54' 0 5/8"	59' 6 5/8"

Run In.	Common Rafter Length	Hip or Val. Rafter Length
1/2	1 1/8"	1 1/4"
1	2 1/8"	2 5/8"
1 1/2	3 1/4"	3 5/8"
2	4 3/4"	4 3/4"
2 1/2	5 3/8"	6"
3	6 1/2"	7 1/8"
3 1/2	7 3/8"	8 3/8"
4	8 3/8"	9 1/2"
4 1/2	9 3/4"	10 3/4"
5	10 3/4"	12"
5 1/2	11 1/8"	13 1/8"
6	13"	14 1/4"
6 1/2	14 1/8"	15 1/2"
7	15 1/8"	16 5/8"
7 1/2	16 1/4"	17 1/8"
8	17 3/8"	19"
8 1/2	18 3/8"	20 1/4"
9	19 1/2"	21 3/8"
9 1/2	20 5/8"	22 5/8"
10	21 5/8"	23 7/8"
10 1/2	22 3/4"	25"
11	23 3/4"	26 1/4"
11 1/2	24 3/8"	27 3/8"

Spacing In.	Jack Rafter Length
1	2 1/4"
2	4 3/8"
3	6 1/2"
4	8 5/8"
5	10 3/4"
6	1' 1"
7	1' 3 1/8"
8	1' 5 1/4"
9	1' 7 1/2"
10	1' 9 5/8"
11	1' 11 1/4"
12	2' 2"
13	2' 4 1/8"
14	2' 6 1/4"
15	2' 8 3/4"
16	2' 10 5/8"
17	3' 0 3/4"
18	3' 2 7/8"
19	3' 5 1/8"
20	3' 7 1/4"
21	3' 9 3/8"
22	3' 11 1/2"
23	4' 1 3/4"
24	4' 3 3/8"

Rafter Thickness	Miter Allowance for Hip and Valley Rafters	Rafter Depth	Bottom Allowance
1 1/2"	1 5/8"	3 1/2"	6 11/16"
1 5/8"	1 3/4"	5 1/2"	10 9/16"
1 3/4"	1 7/8"	7 1/4"	13 7/8"
1 7/8"	2"	9 1/4"	17 3/4"

24 INCH RISE

24-12 PITCH 63½ DEGREES

Run Ft.	Common Rafter Length	Hip or Val. Rafter Length
1	2' 2½"	2' 5¾"
2	4' 5½"	4' 10¾"
3	6' 8½"	7' 4"
4	8' 11¾"	9' 9¾"
5	11' 2½"	12' 3"
6	13' 5"	14' 8¾"
7	15' 7¾"	17' 1¾"
8	17' 10½"	19' 7¾"
9	20' 1½"	22' 0¾"
10	22' 4¾"	24' 6"
11	24' 7¾"	26' 11¾"
12	26' 10"	29' 4¾"
13	29' 0¾"	31' 10½"
14	31' 3½"	34' 3½"
15	33' 6½"	36' 8¾"
16	35' 9¾"	39' 2¾"
17	38' 0¾"	41' 7¾"
18	40' 3"	44' 1¾"
19	42' 5½"	46' 6½"
20	44' 8¾"	48' 11¾"
21	46' 11½"	51' 5¼"
22	49' 2¾"	53' 10¾"
23	51' 5½"	56' 4¾"
24	53' 8"	58' 9½"
25	55' 10¾"	61' 2¾"

Run In.	Common Rafter Length	Hip or Val. Rafter Length
½	1½"	1¼"
1	2¼"	2½"
1½	3¾"	3¾"
2	4½"	4¾"
2½	5½"	6½"
3	6¾"	7¾"
3½	7¾"	8¾"
4	9"	9¾"
4½	10"	11"
5	11½"	12¼"
5½	12½"	13½"
6	13¾"	14¾"
6½	14½"	15½"
7	15½"	17½"
7½	16¾"	18¾"
8	17½"	19¾"
8½	19"	20¾"
9	20½"	22"
9½	21¼"	23¼"
10	22¾"	24½"
10½	23½"	25¾"
11	24½"	27"
11½	25¾"	28¼"

Spacing In.	Jack Rafter Length
1	2¼"
2	4½"
3	6¾"
4	9"
5	11½"
6	1' 1¾"
7	1' 3¾"
8	1' 5¾"
9	1' 8¾"
10	1' 10¾"
11	2' 0¾"
12	2' 2¾"
13	2' 5¾"
14	2' 7¼"
15	2' 9½"
16	2' 11¾"
17	3' 2"
18	3' 4¼"
19	3' 6½"
20	3' 8¾"
21	3' 11"
22	4' 1¼"
23	4' 3¾"
24	4' 5¾"

Rafter Thickness	Miter Allowance for Hip and Valley Rafters	Rafter Depth	Bottom Allowance
1½"	11½/16"	3½"	7"
1⅝"	13/16"	5½"	11"
1¾"	15/16"	7¼"	14½"
1⅞"	2⅛"	9¼"	18½"

